

INSTALLATION and OPERATION MANUAL

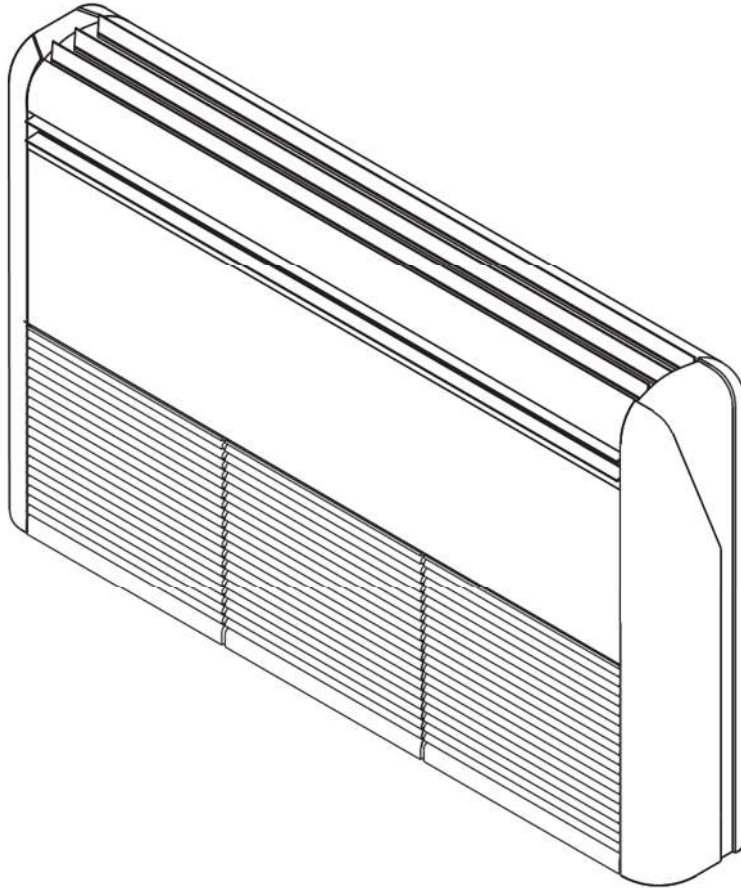

CFFWA4P-XX-1-U Chilled & Hot Water

Universal Mount Fan Coil

4-Pipe Heat & Cool Fan Coil 12,000 - 60,000 BTUH

Read the entire Installation Manual before installing.

CAUTION

Care must be taken when handling sheet metal. Sheet metal parts have sharp edges and could cause injury.

The Multiaqua Fan Coil is designed for indoor installations only. It is not designed to be installed outdoors or in laundry Rooms.

The maximum use altitude for the fan coil is 6000 feet.

The Multiaqua Fan Coil is designed to be installed where accessible to the general public.

This product is designed and manufactured to permit installation in accordance with national codes. It is the installer's responsibility to install the product in accordance with the prevailing Building, Mechanical and Electrical Codes.

This appliance is not intended for use by persons (including children) with reduced physical, sensory or mental capabilities, or lack of experience and knowledge unless they have been given supervision or instruction concerning the use of the appliance by a person responsible for their safety. Children should be supervised to ensure they do not play with the appliance.

Only technicians with training carried out by national training organizations or manufacturers that are accredited to teach the relevant national competency standards that may be set in legislation may work on this equipment. The achieved competence must be documented by a certificate.

Care must be taken to ensure the structural integrity of the supporting members, clearances and provisions for servicing, power supply, coil connections and/or condensate removal.

Installation and servicing of air conditioning equipment can be hazardous due to system pressure and electrical components. Only trained and qualified service personnel should install, repair or service air conditioning equipment.

When working on air conditioning equipment observe precautions in the literature and labels attached to the unit and other safety precautions that may apply.

Follow all safety codes and procedures. Wear safety glasses and work gloves. Use quenching cloth for brazing operations. Have a fire extinguisher available for all brazing operations.

INITIAL CHECK

- (1) Before the installation ensure the structural strength of the supporting members is sufficient. See table 1 for hanging weights of the fan coils.
- (2) The unit should not be removed from the carton unit until reaching final location in order to avoid damage.
- (3) Inspect unit for shipping damage and file a claim with the transport agency if necessary.
- (4) Check to ensure the field electrical is correct for the unit being installed.
 - (a) Proper size of fuses and wire. Connect wiring connections and grounding as specified by the local electrical codes.
 - (b) Check supply voltage, which must be within the limits shown on the nameplate.
- (5) Check for a proper condensate removal. Must be sloped ¼" per foot for proper drainage.
- (6) Be sure piping insulation is adequate to eliminate the possibility of condensate leaking unto the unit or surrounding areas.
- (7) Confirm there are no obstructions to air flow for indoor units. Also check for sufficient

clearances for servicing the unit.

LOCATION & MOUNTING

The unit must be installed in a vertical or horizontal discharge application only. Follow all prevailing codes for proper installation.

Vertical Installation

Necessary space required for installation:

FAN COIL MODEL NUMBER	REQUIRED SPACE W X D X H
CFFWA4P-04-1-U	1934 x 2116 x 2539
CFFWA4P-06-1-U	1934 x 2116 x 2539
CFFWA4P-08-1-U	2234 x 2116 x 2539
CFFWA4P-12-1-U	2534 x 2116 x 2539
CFFWA4P-16-1-U	2834 x 2116 x 2539
CFFWA4P-20-1-U	2834 x 2116 x 2539

Clearances from adjacent structures:

Vertical Installation

Front = 6'

Back = 0

Bottom = 0-6"

Top = 6'

Sides 1'

- (1) See Table1 for hanging weights. Dry coil.
- (2) For unit dimensions, See Table 2
- (3) Select position for unit and define direction of water pipe, drainpipe and electrical wiring.
- (4) Bracket dimension and locations. See Table 3
- (5) Ensure the unit is installed per all prevailing codes.
- (6) Ensure the structural strength of the supporting members is sufficient.
- (7) Remove unit from the carton and carefully place the unit to the installed position and tighten the (4) bolts. See figure 1 and 2
- (8) Secure the unit to the wall using the supplied mounting hardware. See figure 3, 4 and 5

FAN COIL MODEL NUMBER	APPROXIMATED WEIGHTS (lbs)
CFFWA4P-04-1-U	82
CFFWA4P-06-1-U	89
CFFWA4P-08-1-U	95
CFFWA4P-12-1-U	133
CFFWA4P-16-1-U	157
CFFWA4P-20-1-U	168

Table1

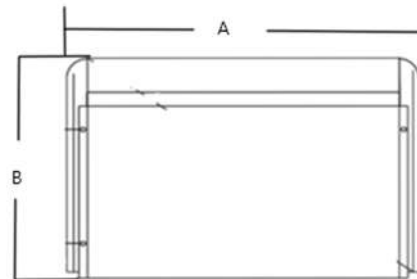

MODEL	A	B
4,6	1324	710
8	1624	710
12	1924	710
16,20	2224	710

Table 2

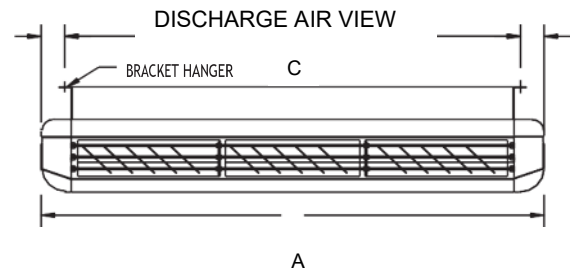
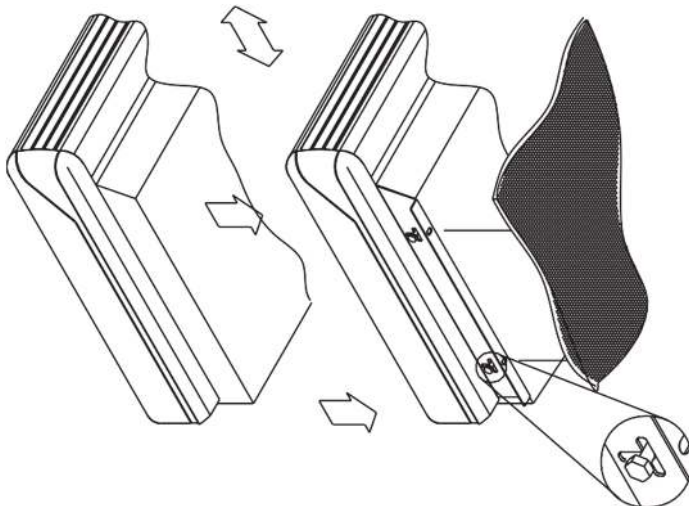

MODEL	C	D
4,6	1227	330
8	1527	330
12	1827	330
16,20	2127	330

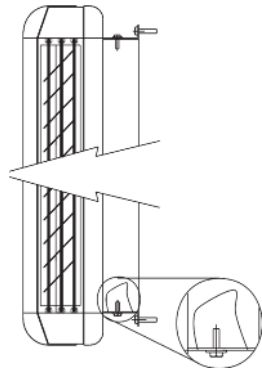

Figure 2

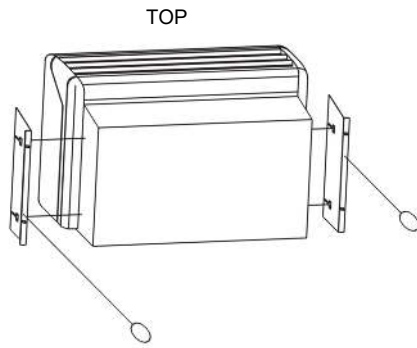

Figure 3

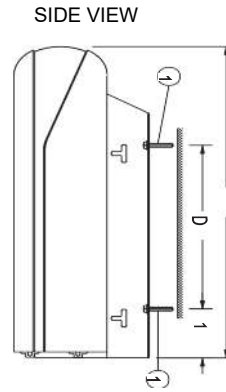

Figure 4

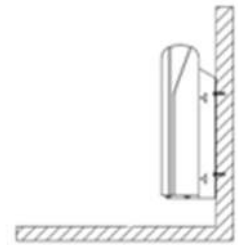

Figure 5

Horizontal Installation

Necessary space required for installation:

FAN COIL MODEL NUMBER	REQUIRED SPACE W X D X H
CFFWA4P-04-1-U	1934 x 2116 x 2539
CFFWA4P-06-1-U	1934 x 2116 x 2539
CFFWA4P-08-1-U	2234 x 2116 x 2539
CFFWA4P-12-1-U	2534 x 2116 x 2539
CFFWA4P-16-1-U	2834 x 2116 x 2539
CFFWA4P-20-1-U	2834 x 2116 x 2539

Clearances from adjacent structures:

Horizontal Installation

- Bottom = 6'
- Top = 0
- Back = 0-6"
- Front = 6'
- Sides 1'

- (1) See Table1 for hanging weights. Dry coil.
- (2) For unit dimensions, See Table 2
- (3) Select position for unit and define direction of water pipe, drainpipe and electrical wiring.
- (4) Bracket dimension and locations. See Table 3
- (5) Ensure the unit is installed per all prevailing codes.
- (6) Ensure the structural strength of the supporting members is sufficient.
- (7) Remove unit from the carton and carefully place the unit to the installed position and tighten the (4) bolts. See figure 6 and 7
- (8) Secure the unit to the ceiling using the supplied mounting hardware. See figure 8, 9 and 10

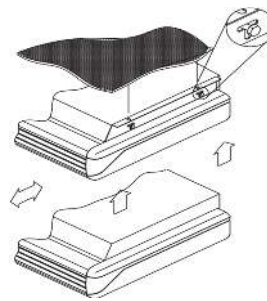

Figure 6

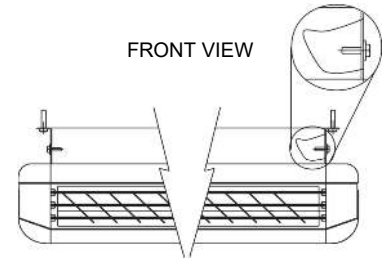

Figure 7

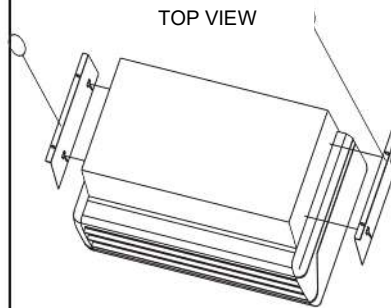

Figure 8

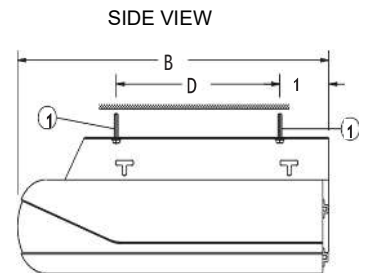

Figure 9

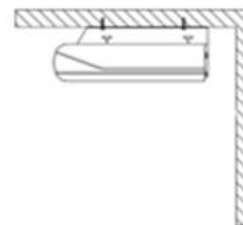

Figure 10

INSTALLATION LOCATION CONSIDERATIONS

When mounting the indoor unit on the ceiling, floor or wall follow the instructions below:

- (1) Select a location that permits the air flow to circulate evenly throughout the room. See figure 11 and 12
- (2) Select a location that has enough Service space when the unit is mounted under the ceiling. See figure 13
- (3) Select a location that has enough service space when the unit is mounted on the floor/wall. See figure 15

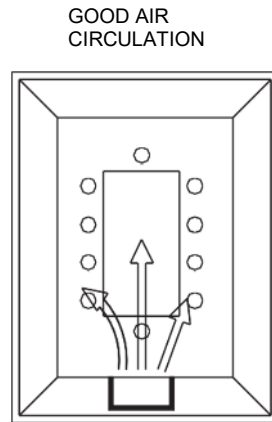

Figure 11

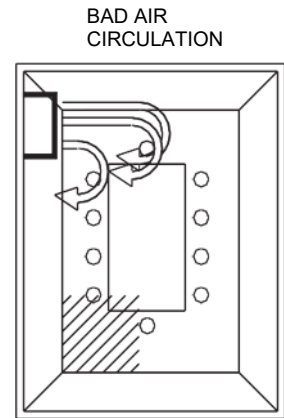

Figure 12

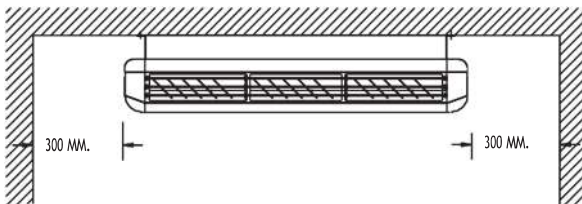

Figure 13

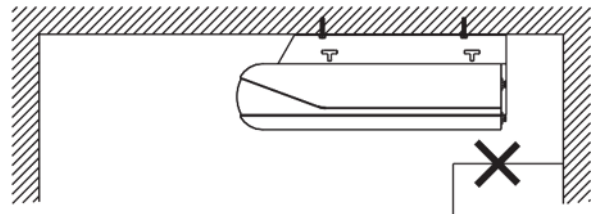

Figure 14

Electrical Connections

The electrical connections are located on the right-hand side of the unit. Unit's side cover will need to be removed for access. See figure 16

Screw terminal blocks have been provided to connect the high voltage wires as well as the thermostat connections. See figure 19

- (1) Electrical ratings. See figure 18
- (2) Be sure to supply power from a dedicated supply circuit per code.
- (3) Wiring should be made in accordance with the applicable prevailing codes.

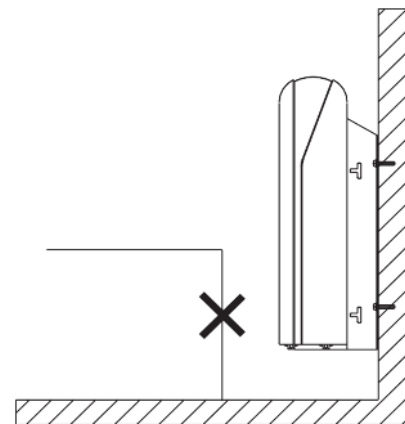

Figure 15

- (4) Refer to the unit's data tag for information relating to MCA and MOP.
- (5) Unit is designed to be hard wired from the breaker circuit.
- (6) Ensure the unit is properly grounded.
- (7) Check for correct correspondence in terminal numbers
- (8) Unit is equipped with three fan relays and a 24vac control transformer. See figure 17 for location
- (9) Any standard 24vac thermostat can be used with this fan coil.
- (10) The unit can run three or single speed fan operations.
- (11) Refer to wiring diagram for the wire connections. See figure 19 and 20
- (12) Secure the cables with a cable clamp after connecting them to the terminal block.
- (13) Power cabling can be executed by authorized electricians only.

FAN COIL MODEL NUMBER	ELECTRICAL RATING	
	MCA	MOCP
CFFWA4P-04-1-U	0.40	15
CFFWA4P-06-1-U	0.93	15
CFFWA4P-08-1-U	1.06	15
CFFWA4P-12-1-U	2.59	15
CFFWA4P-16-1-U	3.40	15
CFFWA4P-20-1-U	3.40	15

Figure 18

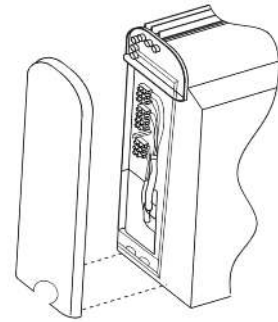

Figure 16

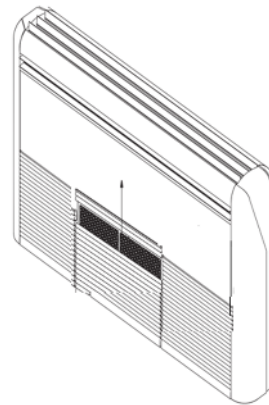

Figure 17

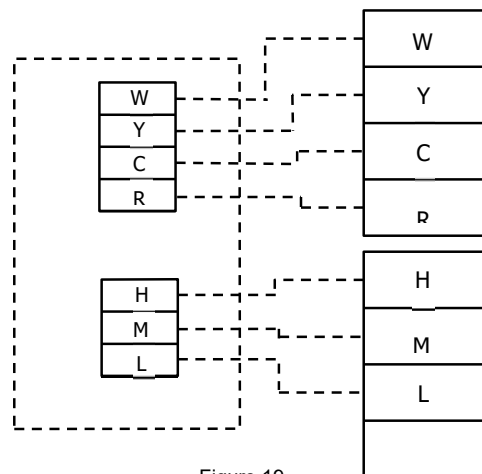
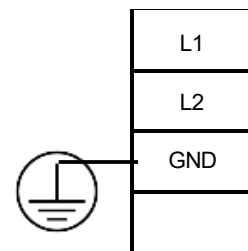

Figure 19

WIRING DIAGRAM FOR CFFWA4P UNIVERSAL MOUNT FANCOIL

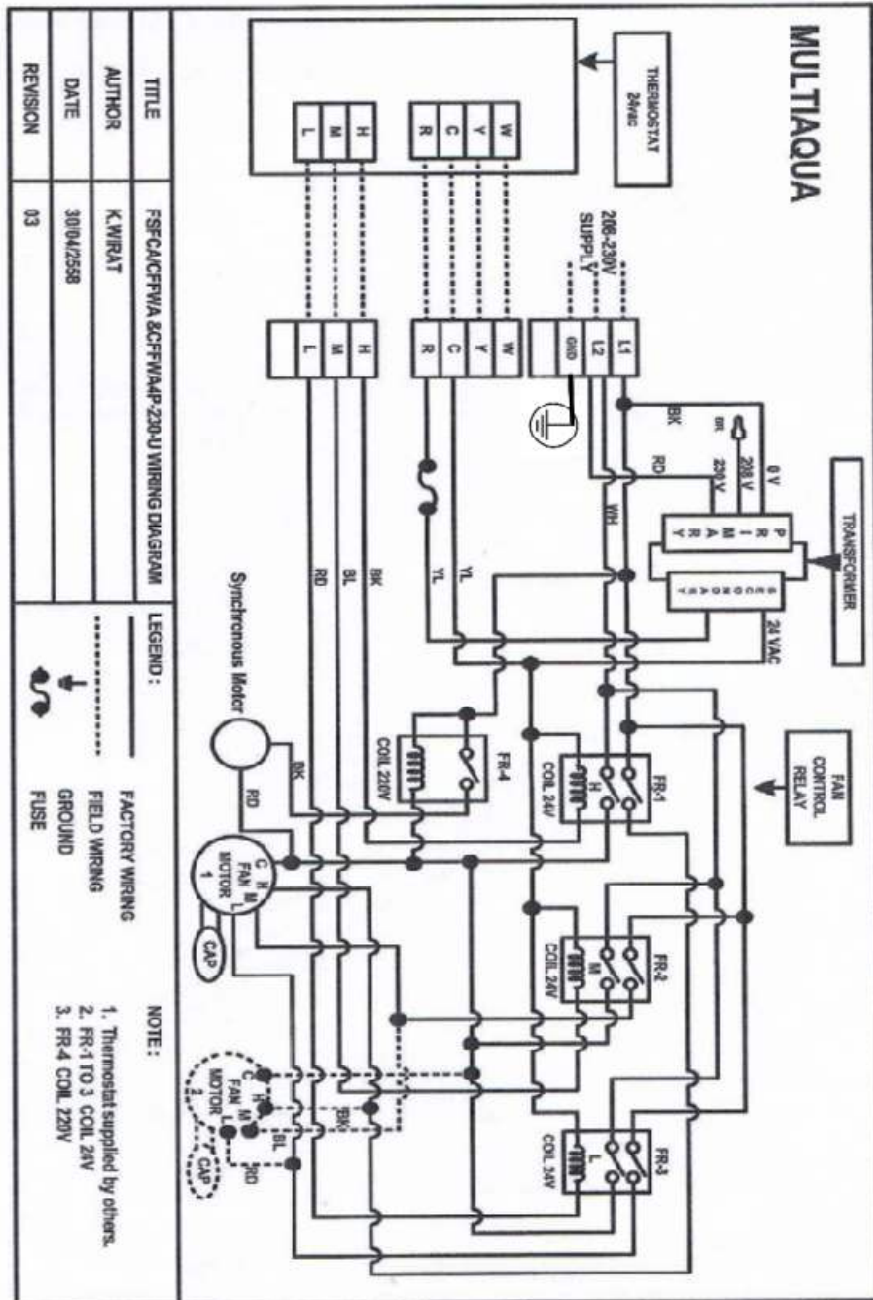

Figure 20

WATER PIPING CONNECTIONS

(1) The CFFWA4P contains a hot and cold-water coil. The cold-water coil piping connections are located behind the lower right-hand side of the return grille. The hot water coil piping connections are located behind the lower left-hand side of the return grille. See figure 21 and 22

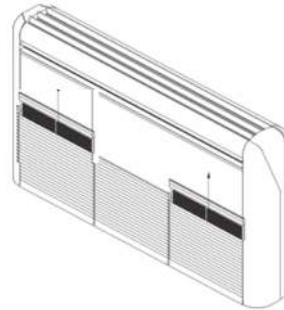

Figure 21

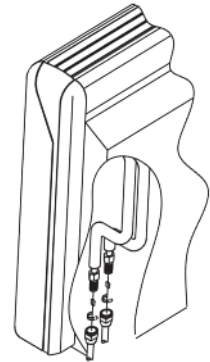

Figure 22

(2) Water piping can enter the unit from the bottom or back of the unit. Figure 23 (Horizontal Discharge Configuration) and 24 (Vertical Discharge Configuration)

(3) The water coil's supply and return lines are copper stub outs. They can be connected to the system's loop by brazing or mechanical connectors. Check prevailing codes for the correct type of connection to be used.

(4) Ensure the supply and return lines of the building's water loop are installed on the correct stub outs inside the unit. The stub outs are labeled supply and return.

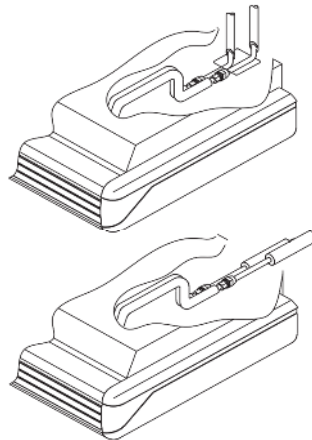

Figure 23

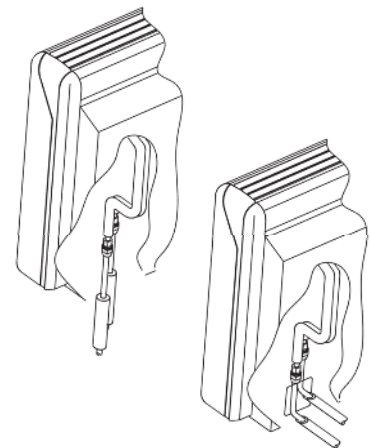

Figure 24

(5) When brazing/soldering the copper lines, use extreme caution as to not burn the surroundings. Use a wet rag in either side of the braze joint to ensure the heat will not travel past the brazing point.

(6) Ensure the water lines are insulated properly to safeguard against sweating and leaking into the unit or the surrounding structure.

(7) Water leak test all brazed/soldered or mechanical connectors to ensure there are no leaks.

CONDENSATE DRAIN

- (1) Be sure the fan coil unit is mounted in level position on the ceiling as well as on the floor/wall.
- (2) The indoor unit uses gravity to drain: therefore, the piping outside the unit should slope downward. $\frac{1}{4}$ " per foot is recommended. See figure 25 and 26
- (3) Avoid draining as shown in figure 27, 28, 29 and 30
- (4) The condensate drain is located behind the lower right-hand side of the return grille. See figure 20
- (5) The drain line has a $\frac{3}{4}$ " soft vinyl pipe for drain connection with a mechanical fitting. Follow prevailing codes for condensate drain installation.
- (6) Ensure the condensate line is insulated properly to safeguard against sweating and leaking into the unit or the surrounding structure.

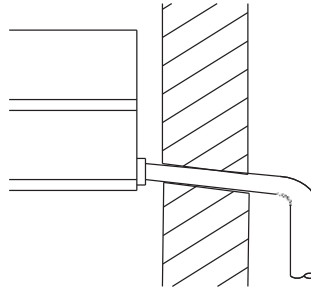

Figure 25

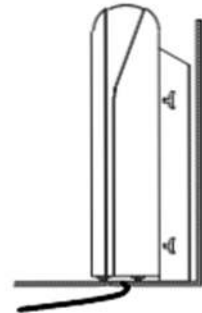

Figure 26

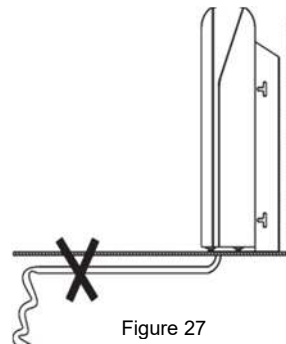

Figure 27

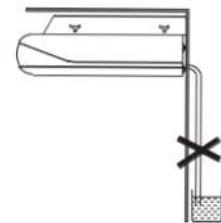

Figure 28

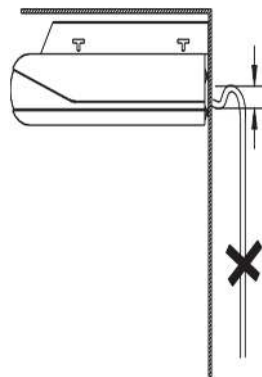

Figure 29

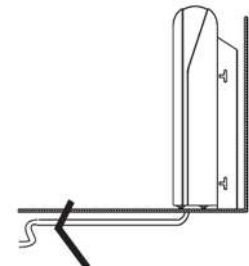
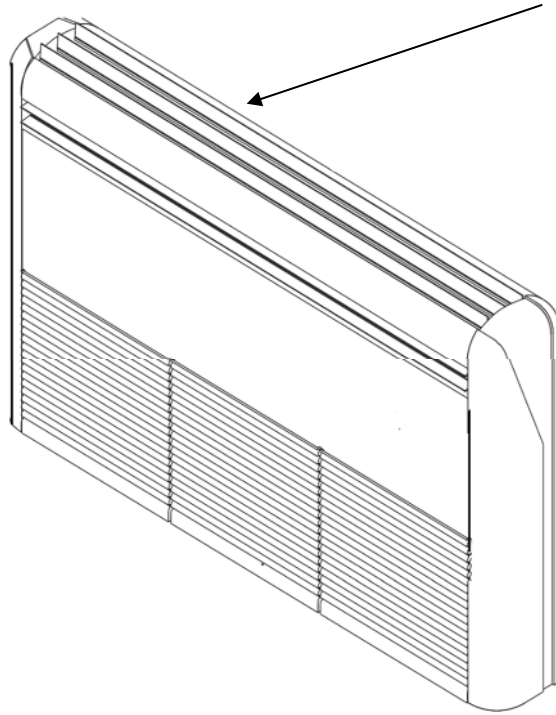

Figure 30

AIR FLOW DIRECTION ADJUSTMENT

To adjust the upward/downward direction of the air current, move the horizontal louvre, be careful to ensure the louvre is not positioned so as to completely cut off the air flow from the unit.



The unit contains a swing motor and swing louvers. This motor oscillates the louvers from left to right in order to distribute the discharge air. It is located under the right-hand side cover of the unit. See figure 31

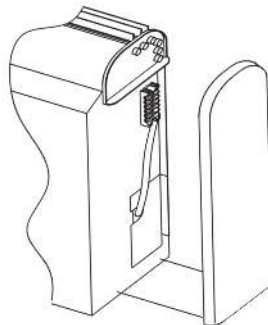

Figure 31

FILTER REMOVAL FOR CLEANING

WARNING ⚠️⚠️

Before performing service or maintenance operations on the system, turn off the main power switches to the unit. Electrical shock could cause personal injury.

Clean filters using a mild detergent and water. Do not use bleach or harsh chemicals.

Pull out the filters for cleaning. See figure 32

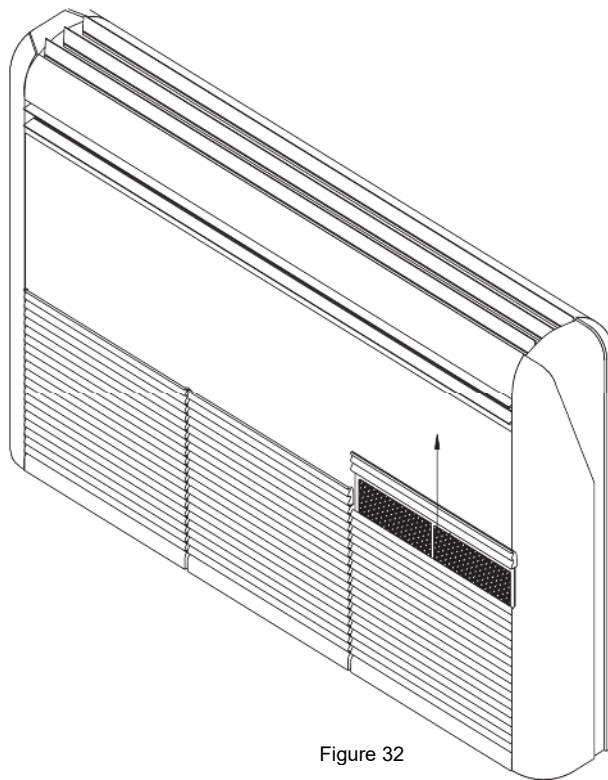

Figure 32

NOTES

