



# **MAC-036HE-01-32-L**

## **High Efficiency Air-Cooled Chiller**

Air-Cooled Chillers for Global  
Residential and Light Commercial

# HVAC Guide Specifications

Air-Cooled Liquid Chiller **with Low Ambient Kit**

Nominal Size:

**3 Tons** Multiaqua

Model Number:

**MAC-036HE-01-32-L**

## **Part 1-General**

### **1.01 System Description**

Multiaqua air-cooled liquid chillers are designed using scroll compressors, low sound condenser fan and high efficiency pump.

### **1.02 Quality Assurance**

- A. Certified in accordance with U.L. UL60335-2-40.
- B. Manufactured in a facility registered to ISO 9002, Manufacturing Quality Standard.
- C. ETL Certified
- D. Fully load tested at the factory.
- E. Damage resistant packaging.

### **1.03 Delivery, Storage and Handling**

- A. Packaged and readied for shipment from the factory.
- B. Controls shall be capable of withstanding 150°F storage temperatures in the control compartment.
- C. Stored and handled per manufacturer's recommendations.

## **Part 2-Product**

### **2.01 Equipment**

#### A. General:

- 1. Unit shall be a factory assembled and tested air-cooled liquid chiller.
- 2. Shall be assembled on heavy gauge steel mounting/lifting rails.
- 3. Contained within the unit cabinet shall be all factory wiring, piping, controls, refrigerant charge (R32), POE oil and special accessories required prior to start up.
- 4. Brass body strainer with 20 mesh screen and blow down shall be supplied in cabinet as a field installable accessory.

#### B. Unit Cabinet:

- 1. Composed of heavy gauge galvanized steel casing with a baked polyester powder.
- 2. Capable of withstanding 500-hour salt spray test in accordance with the ASTM (USA) standard.

#### C. Condenser Fan:

- 1. Four blade glass reinforced polypropylene (PPG) petals mounted on a cast aluminum hub construction and shall be dynamically balanced and corrosion resistant.
- 2. Vertical discharged air.
- 3. Motors and blades shall be protected by coated steel wire safety guards.

#### D. Fan Motors:

- 1. Condenser fan motors shall be single speed, direct drive.
- 2. Totally enclosed.
- 3. Permanently lubricated sleeve bearings and Class F insulation.
- 4. Internal overload protection.

#### E. Compressors:

- 1. Unit shall contain one fully hermetic scroll compressors.
- 2. Direct-drive, 3500 rpm (60Hz)
- 3. Compressor motor shall be suction gas cooled.
- 4. Internal motor protection.
- 5. Externally protected by low and high pressure cutout devices.
- 6. Individual vibration isolators.

## F. Pump:

1. Integral circulating pump shall be stainless steel with high efficiency enclosed motor.
2. Unit shall have chilled liquid solution piping to the exterior of the cabinet.

## G. Evaporator:

1. Evaporator shall have one independent refrigerant circuit and one liquid solution circuit.
2. Rated for a refrigerant side working pressure of 450 psig and a maximum water side working pressure of 60 psig.
3. Single pass, ANSI type 316 stainless steel, brazed plate construction.
4. Externally insulated with closed cell, elastomeric foam. (ASTM518)

## H. Condenser:

1. Condenser coil shall be air-cooled with integral sub-cooler.
2. One independent refrigerant circuit.
3. Constructed of rifled copper tubing mechanically bonded to aluminum fins.
4. Cleaned and dehydrated.
5. Factory leak tested to 450 psig.

## I. Refrigerant Circuits:

1. Each circuit shall contain a sight glass, liquid line filter, thermal expansion valve, refrigerant charge of R32 and POE compressor oil.

**Part 3-Controls and Safeties****3.01 Controls**

- A. Chiller shall be completely factory wired and tested.
- B. Temperature control shall be based on leaving chilled liquid solution temperature.
  1. Temperature accuracy shall be + - 1°F
- C. Controls shall include the following components.
  1. 24vac transformer to serve all controllers relays and control components.
  2. Microprocessor based liquid solution temperature controller.
  3. Leaving water temperature thermistor.
  4. Pump bypass timer.
  5. Compressor recycle timer.
  6. Optional low pressure bypass timer for low ambient operation.
  7. Optional fan cycling control for low ambient operation.
  8. Chilled liquid solution flow switch.

**3.02 Safeties**

- A. Unit shall be equipped with thermistors and all necessary components in conjunction with the control system to provide the following protectants.
  1. Low refrigerant pressure.
  2. High refrigerant pressure.
  3. Low chilled liquid solution temperature.
  4. Low chilled liquid solution flow.
  5. Thermal overload.
  6. Short cycling.

**Part 4-Operating Characteristics:****4.01 Temperatures**

- A. Unit shall be capable of starting and running at outdoor temperatures from 55°F to 120°F.
- B. Optional Low Ambient Kit shall allow starting and running at outdoor temperatures to -20°F. A field supplied and installed crankcase heater must be used when operating at these temperatures.
- C. Unit shall be capable of starting up with a maximum 80°F and a sustained 70°F entering fluid solution temperature to the evaporator.
- D. Minimum 10% Glycol solution is always required.
- E. For outdoor temperatures below 32°F, reference MAC Glycol Solution Data table.

**4.02 Electrical Requirements**

- A. Primary electrical power supply shall enter the unit at a single location.
- B. Electrical power supply shall be rated to withstand 120°F operating ambient temperature.
- C. Units shall be available in 1 or 3-phase power at the voltages shown in the equipment electrical data.
- D. Control points shall be accessed through terminal block.

**Part 5- Definitions:****5.01 Abbreviations**

- A. CFM = Cubic Feet per Minute
- B. DB = Dry Bulb Temperature
- C. EWT = Entering Water Temperature
- D. GPM = US Gallons Per Minute
- E. MBH = BTU X 1000
- F. SC = Sensible Cooling
- G. TC = Total Cooling = Sensible + Latent
- H. WB = Wet Bulb Temperature
- I. WPD = Water Pressure Drop in feet of head
- J. dB = Decibel Level
- K. m = Meter

**5.02 Measurements**

- A. All measurements with regard to length, width, and height shall be in inches.

# MAC-036HE-01-32-L Specifications

Physical Data						
Model Number	Chiller			Weight (lbs.)		Shipping
	Height (in)	Length (in)	Width (in)	Refrigerant R32	Net	
MAC-036HE-01-32	57.75	35.25	40.875	7 LBS	575	805

Electrical Data								
With Integral Circulating Pump								
Model Number	Volts/ Phase/ Hertz	Compressor		Condenser Fan Motor		Pump Motor	Fuse or HACR Circuit Breaker	
		(RLA)	(LRA)	(RLA)	(RPM)		Minimum Amps(MCA)	Maximum Amps(MOCP)
MAC-036HE-01-32	208/230-1-50/60	19.5	121.5	2.5	1130	3.7	30.58	50

Electrical Data								
Without Integral Circulating Pump								
Model Number	Volts/ Phase/ Hertz	Compressor		Condenser Fan Motor		Fuse or HACR Circuit Breaker		
		(RLA)	(LRA)	(RLA)	(RPM)	Minimum Amps(MCA)	Maximum Amps(MOCP)	
MAC-036HE-01-32	208/230-1-50/60	19.5	121.5	2.5	1130	26.88		45

Compressor	Copeland Scroll
Refrigerant	R32
Heat Exchanger	Brazed Plate
Max. Pump Head Pressure	50ft.
Internal Pressure Drop	8.5 Ft. of Head
Max. Flow Rate	8.5 gpm
Min. Flow Rate	7.0 gpm
Supply Water Temp	44°
Return Water Temp	54°
Minimum System Solution Content	25 Gallons
Expansion Tank Size	2 Gallons
Water Connections	1" MPT Supply & 1.25" MPT Return
Pump	½ HP

Multi-aqua chillers are designed to operate exclusively with R32 refrigerant in a self-contained, pre-charged refrigerant system. Do not access the closed refrigerant circuit for any reason other than after-sale, after installation component replacement. Routine maintenance and service is to be performed by qualified personnel only.

# MAC-036HE-01-32-L Product Specifications

<b>Glycol Solution Concentration Data</b>	
Propylene Glycol %	Min. Ambient Temp
10%	26°F
20%	18°F
30%	8°F
40%	-7°F
50%	-29°F

<b><u>Estimated Propylene Glycol Adjustment Factors:</u></b>		
Percent of Propylene Glycol	Capacity adjustment Multiply TONS by:	Pressure Drop adjustment Multiply PD by:
10%	0.995	1.02
15%	0.992	1.04
20%	0.986	1.08
25%	0.972	1.13
30%	0.96	1.21
35%	0.95	1.26
40%	0.928	1.47
50%	0.878	2.79

## **Important**

### **Required Use of 10% Minimum Propylene Glycol**

MultiAqua Inc. requires a minimum concentration of 10% propylene glycol in the chiller system solution. This requirement applies to all chiller product models for protection of the brazed plate heat exchanger (BPHE), **regardless of outdoor ambient operating temperature.**

The MultiAqua chiller operating at a 44 leaving water temperature (LWT) will have an internal BPHE temperature of 32 F to 38 F. Without the required MINIMUM 10% concentration of propylene glycol, the unit is susceptible to areas of freezing within the BPHE which could result in failure of the BPHE.

With any deviation from full flow through the BPHE, the BPHE would also be susceptible to areas of freezing within the BPHE. This could be caused by, but not limited to, contaminants being caught in the wye strainer, flow switch or pump failure. Each chiller is supplied from the factory with a Wye strainer that is to be installed on the inlet (suction) side of the pump on the MAC- 036HE, 048HE, 060HE, and MAC120HE chillers.

**Failure to follow this requirement will void the chiller warranty.** Failure to comply may result in BPHE failure due to freezing followed by compressor failure, all of which are not covered by MultiAqua's warranty.

# MAC-036HE-01-32-L Specifications

LWT (F)	ENTERING AIR TEMPERATURE				LWT (F)	ENTERING AIR TEMPERATURE				LWT (F)	ENTERING AIR TEMPERATURE			
	70°F					80°F					95°F			
	BTU's	TONS	EER	COP		BTU's	TONS	EER	COP		BTU's	TONS	EER	COP
35	37084	3.09	16.91	4.84	35	34584	2.88	14.77	4.21	35	34649	2.89	12.55	3.57
40	39318	3.28	17.92	5.14	40	36815	3.07	15.77	4.51	40	36397	3.03	13.15	3.74
42	40631	3.39	18.25	5.23	42	38391	3.20	16.36	4.68	42	34963	2.91	13.63	3.88
44	41926	3.49	18.55	5.32	44	39752	3.31	16.74	4.79	44	36359	3.03	14.07	4.01
45	42944	3.58	19.00	5.45	45	40517	3.38	16.97	4.86	45	36937	3.08	14.17	4.04
48	45077	3.76	19.67	5.65	48	42819	3.57	17.80	5.10	48	39004	3.25	14.83	4.23
50	46351	3.86	19.90	5.72	50	44443	3.70	18.35	5.26	50	40390	3.37	15.21	4.34
55	47992	4.00	20.43	5.87	55	46219	3.85	19.00	5.45	55	41818	3.48	15.59	4.46
60	50896	4.24	20.83	6.14	60	49325	4.11	20.08	5.77	60	44546	3.71	16.41	4.69

LWT (F)	ENTERING AIR TEMPERATURE				LWT (F)	ENTERING AIR TEMPERATURE				LWT (F)	ENTERING AIR TEMPERATURE			
	100°F					105°F					110°F			
	BTU's	TONS	EER	COP		BTU's	TONS	EER	COP		BTU's	TONS	EER	COP
35	30433	2.54	11.60	3.29	35	29442	2.45	10.96	3.10	35	28348	2.36	10.26	2.89
40	32096	2.67	12.17	3.45	40	30990	2.58	11.43	3.24	40	29794	2.48	10.67	3.01
42	33472	2.79	12.61	3.58	42	32240	2.69	11.80	3.34	42	30647	2.55	10.80	3.05
44	34943	2.91	13.10	3.73	44	33871	2.82	12.39	3.52	44	32263	2.69	11.37	3.22
45	35724	2.98	13.34	3.80	45	34628	2.89	12.61	3.58	45	33162	2.76	11.69	3.31
48	37542	3.13	13.84	3.94	48	35779	2.98	12.70	3.61	48	34242	2.85	11.75	3.33
50	38880	3.24	14.19	4.05	50	37034	3.09	13.01	3.70	50	35604	2.97	12.13	3.44
55	39840	3.32	14.29	4.07	55	38517	3.21	13.45	3.83	55	37225	3.10	12.65	3.59
60	42398	3.53	15.00	4.28	60	40596	3.38	13.88	4.08	60	39037	3.25	12.94	3.68

LWT (F)	ENTERING AIR TEMPERATURE				LWT (F)	ENTERING AIR TEMPERATURE			
	115°F					120°F			
	BTU's	TONS	EER	COP		BTU's	TONS	EER	COP
35	26992	2.25	9.43	2.65	35	24370	2.03	7.98	2.23
40	28908	2.41	10.12	2.85	40	26173	2.18	8.58	2.40
42	29743	2.48	10.24	2.89	42	27384	2.28	8.92	2.50
44	30630	2.55	10.39	2.93	44	28162	2.35	9.02	2.53
45	31700	2.64	10.80	3.05	45	29077	2.42	9.33	2.62
48	33080	2.76	11.06	3.13	48	30568	2.55	9.67	2.72
50	34287	2.86	11.35	3.21	50	31464	2.62	9.81	2.76
55	35718	2.98	11.76	3.33					
60	37443	3.12	12.02	3.41					

## MAC-036HE-01-32-L Specifications

	Entering Air Temperature			
	<b>95°F</b>			
Percent of Load %	<u>100%</u>	<u>75%</u>	<u>50%</u>	<u>25%</u>
LWT (°F)	44°F	44°F	44°F	44°F
Capacity Point Btu/hr.	36359	40694	42528	42701
Capacity Point Tons	3.03	3.39	3.54	3.56
EER	14.07	17.35	20.89	23.19
<b><u>IPLV</u></b>	<b>19.61</b>			



The factory provided expansion tank and air/gas purge must be field installed outside of the Chiller's cabinet and outside of any building. This device must be installed at an elevation above the height of the chiller's brazed plate heat exchanger. This device will automatically vent out micro air bubbles that are trapped in the system.

In the event of a rupture in the refrigerant/ liquid solution brazed plate heat exchanger, the air purge will vent the refrigerant out of the liquid solution lines in order to prevent the refrigerant from entering the conditioned space via the liquid solution piping.

Ensure that the device does not vent near any continuously operating ignition source (for example: open flames, an operating gas appliance or an operating electric heater)

## MAC-036HE-01-32-L Altitude Adjustment Factors

Altitude	Tons
1000 ft.	.995
2000 ft.	.990
3000 ft.	.986
4000 ft.	.983
5000 ft.	.980
6000 ft.	.978

# MAC-036HE-01-32-L Chiller Pump Curve

Pump Model Number  
**C14311BBTVF/C14311-3600**  
 (208/230-1-50/60)  
 0.5 Horsepower



**AMERICAN STAINLESS PUMPS**  
 Stainless Steel Pumps for the Commercial Marketplace

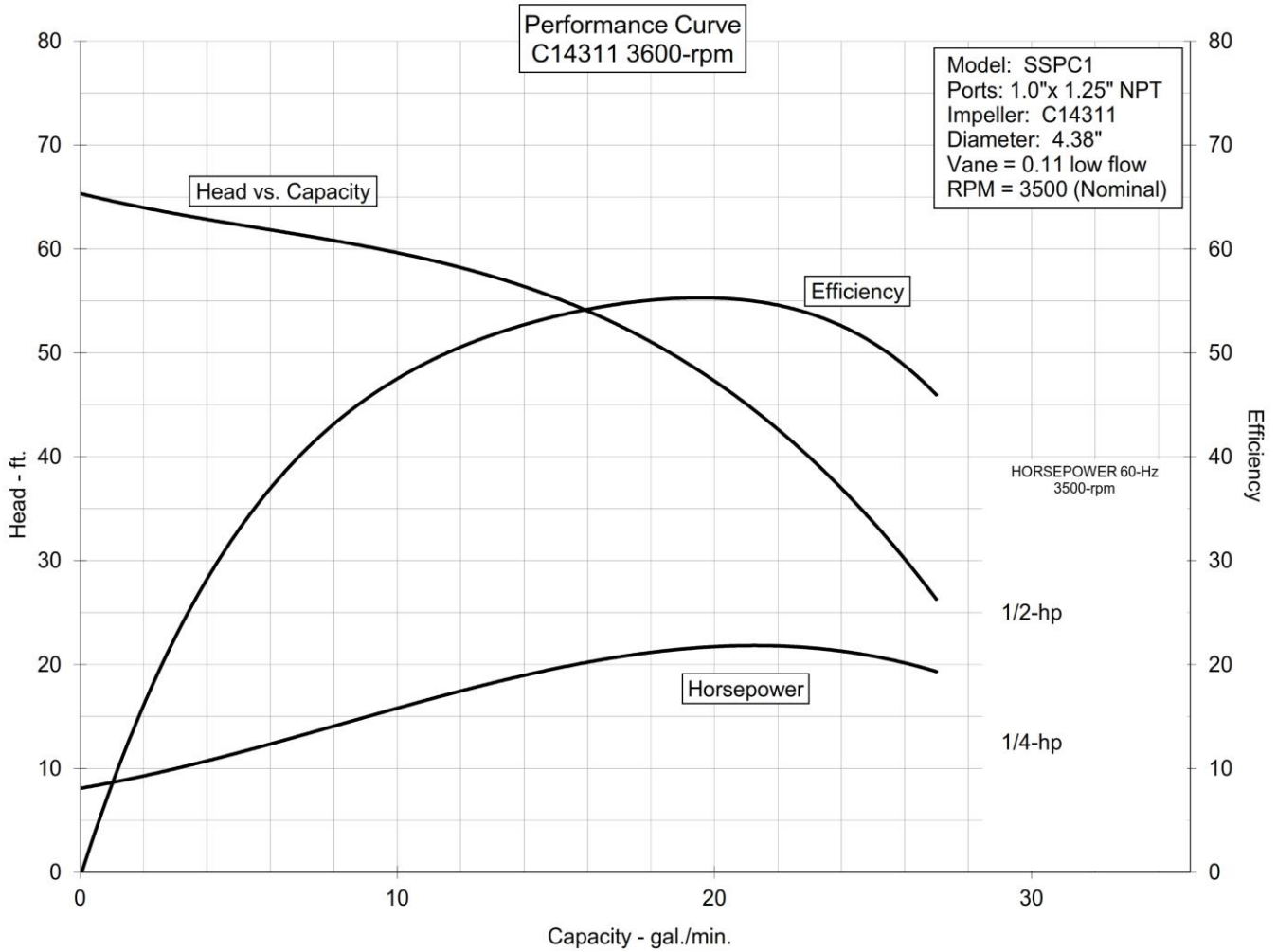

www.aspumps.com

14032 Avalon Blvd. Los Angeles CA 90061  
 Phone (310) 630-8089 ~ Fax (310) 630-8095

C14311-3500  
 2/24/2012

# MAC-036HE-01-32-L Sound Data

MODEL #	MAC-036HE
Fan Speed	dB @ 3 m
H	69

## MAC-036HE-01-32-L Wiring Diagram

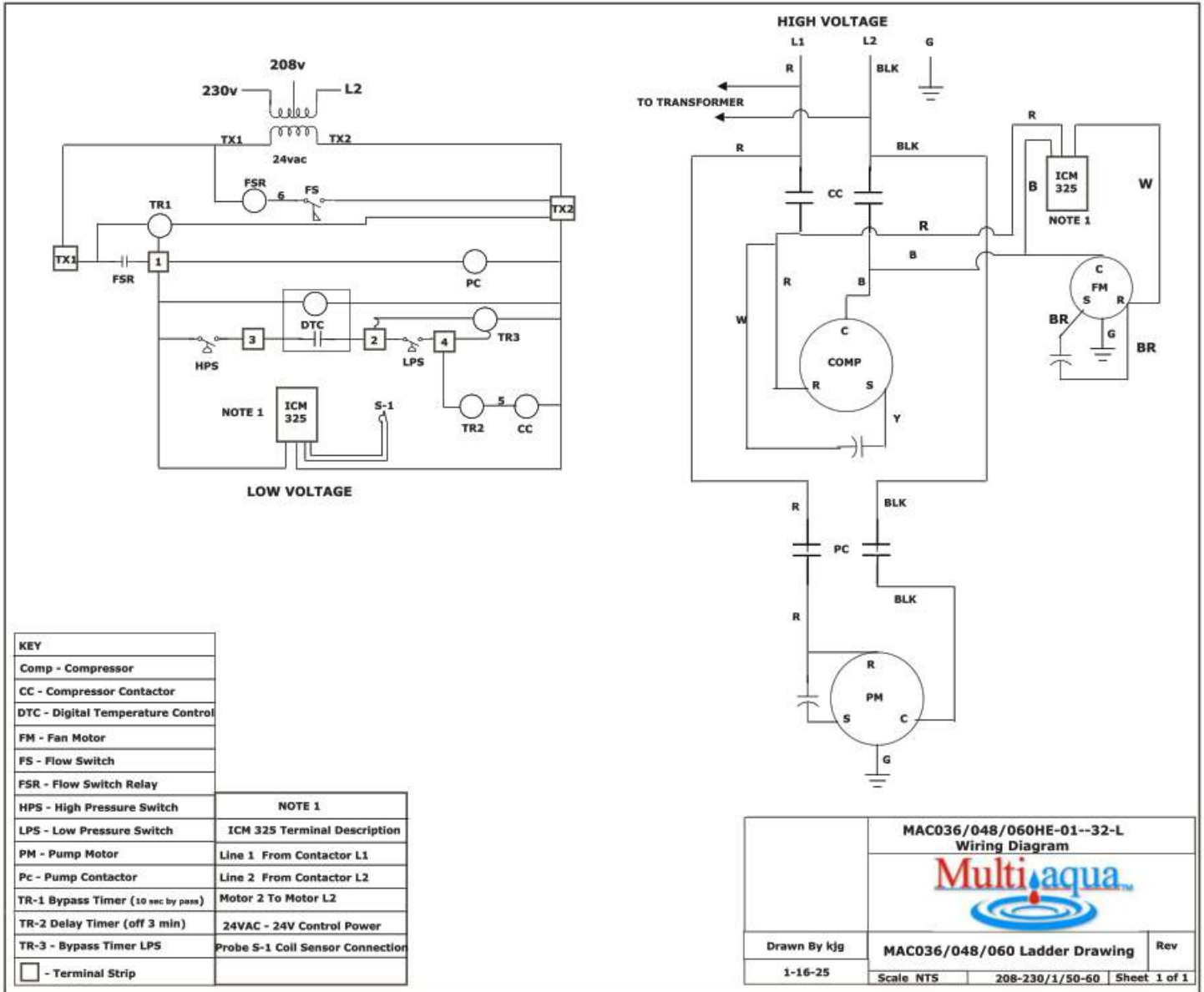

# MAC-036HE-01-L Dimensional Drawing

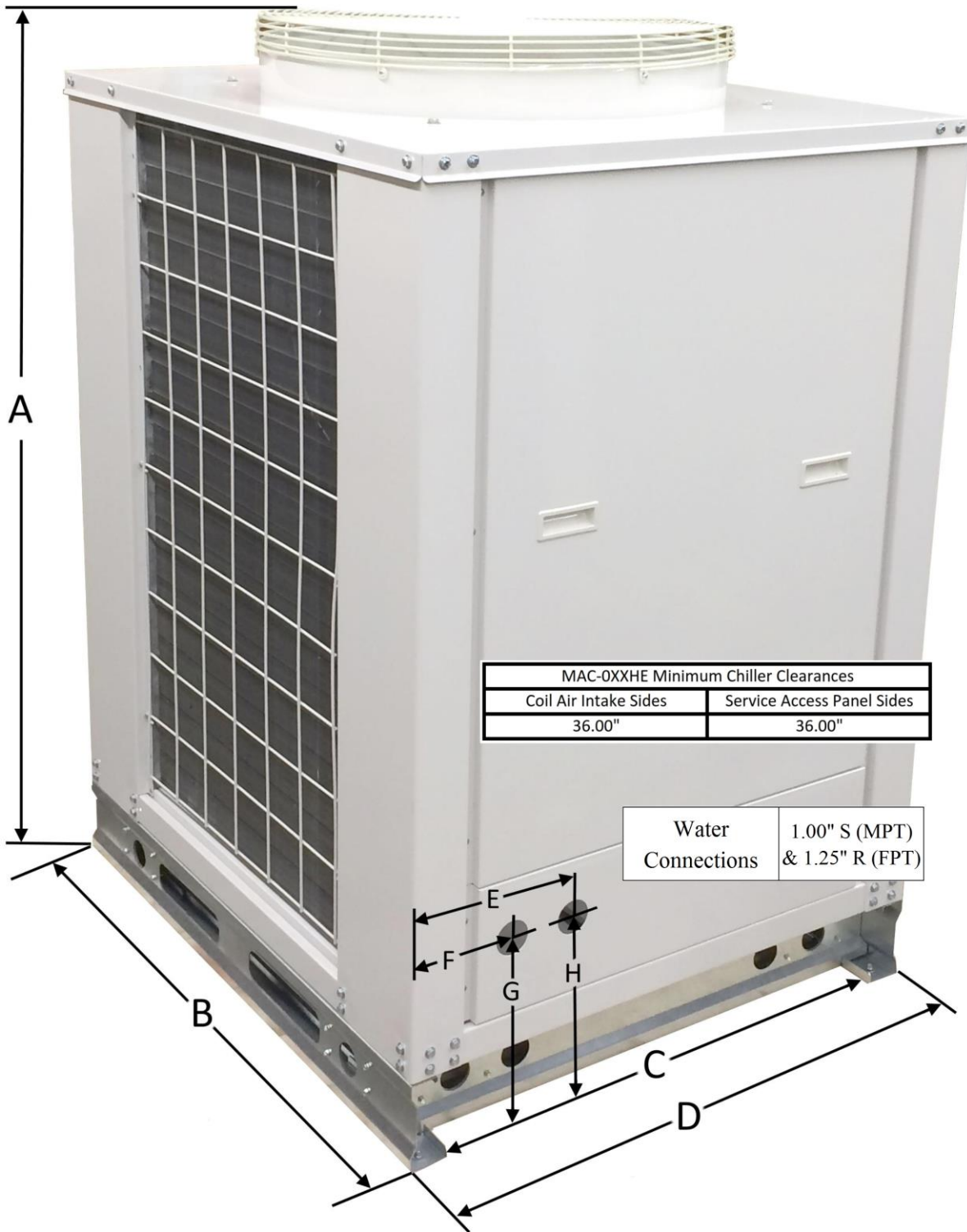

MODEL	A	B	C	D	E	F	G	H
MAC-036HE	57.75"	40.875"	30.75"	35.25"	10.25"	6.25"	11.5"	11.5"

These specifications are subject to change without notice.  
Check [www.multiaqua.com](http://www.multiaqua.com) for the latest information.



306 Hagood Street  
Easley, SC 29640  
Ph: 864-850-8990  
Fax: 864-850-8995  
[www.multiaqua.com](http://www.multiaqua.com)

For Technical Assistance:  
1-855-THNK-WTR (1-855-846-5987)

*These specifications are subject to change without notice.  
Check [www.multiaqua.com](http://www.multiaqua.com) for the latest information.*