



MCCW-20-H-1 Chilled Water Ceiling Concealed Without Electric Heat

2-Pipe Hydronic Heat / Cool Fan Coil 60,000 BTUH

HVAC Guide Specifications

Chilled and Hot Water Fan Coil
2-Pipe

Nominal Size:
60,000 BTUH

MultiAqua Model Number:
MCCW-20-H-1

Part 1-General

1.01 System Description

MultiAqua Chilled Water Fan Coils are manufactured with heavy gauge galvanized steel to resist corrosion.

1.02 Quality Assurance

- A. Certified in accordance with U.L. Standard 95, latest version (U.S.A.)
- B. Manufactured in a facility registered to ISO 9002, Manufacturing Quality Standard.
- C. Fully load tested at the factory.
- D. Damage resistant packaging.

1.03 Delivery, Storage and Handling

- A. Packaged and readied for shipment from the factory.
- B. Controls shall be capable of withstanding 150°F storage temperatures in the control compartment.
- C. Stored and handled per manufacturer's recommendations.

Part 2-Product

2.01 Equipment

- A. General:
 - 1. Unit shall be a factory assembled and tested chilled and hot water fan coil.
 - 2. Shall be assembled with heavy gauge galvanized steel.
 - 3. Contained with the unit shall be all factory wiring, piping, associated controls and special accessories required prior to start up.
- B. Unit Cabinet:
 - 1. Composed of heavy gauge galvanized steel casing with a baked polyester powder.
 - 2. Shall be internally insulated to ensure quiet operation.
- C. Fan Motors:
 - 1. Shall be available in 208/230-1-50/60 VAC.
 - 2. Fan motors shall be three speed, direct drive, and PSC type.
 - 3. Totally enclosed.
 - 4. Internal overload protected.
- D. Blower Wheels:
 - 1. Blower wheels are forward curved and dynamically balanced.
- E. Water Coil:
 - 1. Manufactured with water coils containing 3/8" copper tubing mechanically bonded to aluminum fins.
 - 2. Contain both a manual water drain and manual air bleed port per coil.
 - 3. Maximum operating pressure is 150 psig.
- F. Drain Pan:
 - 1. All drain pans shall be coated on both the interior and exterior with baked polyester powder to resist corrosion.
 - 2. The exterior of all drain pans shall be insulated with closed cell insulation to prevent condensation.
 - 3. Pans shall contain a left hand (looking in the direction of air flow) primary and secondary sloped drain connection.

Part 3-Controls and Safeties**3.01 Controls**

- A. Fan coils shall be completely factory wired and tested.
- B. All components shall be wired to an internal terminal block to allow for a field installed thermostat and or fan speed control.
- C. Controls shall include the following components.
 - 1. 24vac transformer
 - 2. Fan relays
 - 3. Optional thermostats

3.02 Safeties:

- A. Fan coil shall contain a non-reusable fuse on the secondary voltage side of the transformer.

Part 4-Operating Characteristics**4.01 Electrical Requirements**

- A. Primary electrical power supply shall enter the unit at a single location.
- B. Electrical power supply shall be rated to withstand 120°F operating ambient temperatures.
- C. Control and high voltage points shall be accessed through terminal block.

Part 5- Definitions**5.01 Abbreviations**

- A. CFM = Cubic Feet per Minute
- B. DB = Dry Bulb Temperature
- C. EWT = Entering Water Temperature
- D. GPM = US Gallons Per Minute
- E. MBH = BTU X 1000
- F. SC = Sensible Cooling
- G. TC = Total Cooling = Sensible + Latent
- H. WB = Wet Bulb Temperature
- I. WPD = Water Pressure Drop in feet of head
- J. dB = Decibel Level
- K. m = Meter
- L. In = Inches
- M. FPI = Fins per Inch
- N. OD = Outside Diameter
- O. ID = Inside Diameter
- P. MCA = Minimum Circuit Amps
- Q. MOP = Maximum Over current Protection
- R. LBS = Pounds U.S.

5.02 Measurements

- A. All measurements with regard to length, width, and height shall be in inches.

MCCW-20-H-1 Product Specifications

| Physical Data | | | | | | | | | |
|---------------|-------------|-------------|------------|--------------|------------------|----------------------|------------------|-------------------|------------|
| Model Number | Height (in) | Length (in) | Depth (in) | Weight (lbs) | Cooling Rows FPI | Copper Diameter (in) | Water Inlet (in) | Water Outlet (in) | Drain (in) |
| MCCW-20-H-1 | 13.78 | 56.10 | 20.00 | 72.80 | 3-14 | 3/8 | 1.0 | 1.0 | 1/2 |

| Electrical Data | | | | | | |
|-----------------|-------------|---------------------|----------|--------------------|--|-----|
| Model Number | Nominal CFM | Volts/ Phase/ Hertz | Motor HP | Full Load Ampacity | Fuse or HACR Circuit Breaker Per Circuit | |
| | | | | | MCA | MOP |
| MCCW-20-H-1 | 1435 | 208/230-1-50/60 | 1/2 | 2.72 | 3.40 | 8 |

MCCW-20-H-1 Chilled Water Performance Data

| MCCW-20 COOLING CAPACITIES | | | | |
|----------------------------|----------|-------|------------------------------|---------------------|
| CFM | EWT (°F) | GPM | ENTERING AIR TEMPERATURE (F) | |
| | | | | 80° D.B. / 67° W.B. |
| 1435 | 42 | 8.75 | TC | 53243 |
| | | | SC | 37981 |
| | | | WPD | 17.9 |
| | | 9.75 | TC | 55397 |
| | | | SC | 38893 |
| | | | WPD | 21.8 |
| | | 10.75 | TC | 57200 |
| | | | SC | 39664 |
| | | | WPD | 26.1 |
| | | 11.75 | TC | 58732 |
| | | | SC | 40313 |
| | | | WPD | 30.8 |

***High Speed**

| MCCW-20 COOLING CAPACITIES | | | | |
|----------------------------|----------|-------|------------------------------|---------------------|
| CFM | EWT (°F) | GPM | ENTERING AIR TEMPERATURE (F) | |
| | | | | 80° D.B. / 67° W.B. |
| 1435 | 45 | 8.75 | TC | 47614 |
| | | | SC | 35669 |
| | | | WPD | 17.8 |
| | | 9.75 | TC | 49365 |
| | | | SC | 36433 |
| | | | WPD | 21.7 |
| | | 10.75 | TC | 50914 |
| | | | SC | 37066 |
| | | | WPD | 26.0 |
| | | 11.75 | TC | 52338 |
| | | | SC | 37662 |
| | | | WPD | 30.6 |

***High Speed**

Recommended minimum flow rate for this unit at ≥ 2 fps is 4.0 gpm

Recommended maximum flow rate for this unit at ≤ 6 fps is 11.75 gpm

MCCW-20-H-1 Hot Water Performance Data

MCCW-20 HOT WATER CAPACITIES

| ENTERING AIR (°F) | NOMINAL CFM | GPM | WPD | ENTERING WATER TEMPERATURE (°F) | | | | | | | | | |
|-------------------|-------------|-------|------|---------------------------------|-------|-------|-------|-------|--------|--------|--------|--------|--------|
| | | | | 90° | 100° | 110° | 120° | 130° | 140° | 150° | 160° | 170° | 180° |
| 50 | 1435 | 8.75 | 16.5 | 47086 | 58850 | 70648 | 82472 | 94316 | 106176 | 118046 | 129922 | 141803 | 153684 |
| | | 9.75 | 20.2 | 47931 | 59909 | 71919 | 83954 | 96009 | 408078 | 120158 | 132244 | 144334 | 156426 |
| | | 10.75 | 24.1 | 48629 | 60782 | 72966 | 85175 | 97402 | 109643 | 121894 | 134152 | 146414 | 158677 |
| | | 11.75 | 28.4 | 49215 | 61515 | 73844 | 86196 | 98567 | 110951 | 123345 | 135745 | 148149 | 160556 |

MCCW-20 HOT WATER CAPACITIES

| ENTERING AIR (°F) | NOMINAL CFM | GPM | WPD | ENTERING WATER TEMPERATURE (°F) | | | | | | | | | |
|-------------------|-------------|-------|------|---------------------------------|-------|-------|-------|-------|-------|--------|--------|--------|--------|
| | | | | 90° | 100° | 110° | 120° | 130° | 140° | 150° | 160° | 170° | 180° |
| 60 | 1435 | 8.75 | 16.2 | 35468 | 47209 | 58986 | 70791 | 82620 | 94465 | 106322 | 118188 | 130059 | 141932 |
| | | 9.75 | 19.7 | 36092 | 48047 | 60037 | 72054 | 84093 | 96148 | 108216 | 120291 | 132372 | 144456 |
| | | 10.75 | 23.6 | 36607 | 48738 | 60903 | 73094 | 85305 | 97533 | 109772 | 122020 | 134273 | 146528 |
| | | 11.75 | 27.8 | 37040 | 49318 | 61629 | 73964 | 86320 | 98691 | 111073 | 123463 | 135859 | 148257 |

MCCW-20 HOT WATER CAPACITIES

| ENTERING AIR (°F) | NOMINAL CFM | GPM | WPD | ENTERING WATER TEMPERATURE (°F) | | | | | | | | | |
|-------------------|-------------|-------|------|---------------------------------|-------|-------|-------|-------|-------|-------|--------|--------|--------|
| | | | | 90° | 100° | 110° | 120° | 130° | 140° | 150° | 160° | 170° | 180° |
| 70 | 1435 | 8.75 | 16.4 | 23839 | 35559 | 47317 | 59106 | 70920 | 82752 | 94598 | 106454 | 118317 | 130183 |
| | | 9.75 | 20.0 | 24244 | 36178 | 48149 | 60150 | 72175 | 84218 | 96274 | 108341 | 120414 | 132491 |
| | | 10.75 | 24.0 | 24578 | 36689 | 48836 | 61011 | 73208 | 85424 | 97652 | 109891 | 122136 | 134385 |
| | | 11.75 | 28.3 | 24859 | 37117 | 49410 | 61731 | 74073 | 86432 | 98804 | 111186 | 123574 | 135966 |

MCCW-20 HOT WATER CAPACITIES

| ENTERING AIR (°F) | NOMINAL CFM | GPM | WPD | ENTERING WATER TEMPERATURE (°F) | | | | | | | | | |
|-------------------|-------------|-------|------|---------------------------------|-------|-------|-------|-------|-------|-------|-------|--------|--------|
| | | | | 90° | 100° | 110° | 120° | 130° | 140° | 150° | 160° | 170° | 180° |
| 80 | 1435 | 8.75 | 16.1 | 12197 | 23896 | 35636 | 47409 | 59208 | 71028 | 82863 | 94710 | 106564 | 118424 |
| | | 9.75 | 19.7 | 12384 | 24298 | 36251 | 48236 | 60247 | 72277 | 84323 | 96380 | 108445 | 120515 |
| | | 10.75 | 23.6 | 12538 | 24629 | 36758 | 48918 | 61102 | 73305 | 85523 | 97752 | 109989 | 122232 |
| | | 11.75 | 27.7 | 12668 | 24907 | 37183 | 49488 | 61817 | 74165 | 86526 | 98899 | 111279 | 123664 |

Heating at ANSI/AHRI 440 with addendum 1, 6.3.2 Table 1 as follows:

| ENTERING AIR TEMPERATURE | GPM | ENTERING WATER TEMPERATURE 140F |
|--------------------------|-------|---------------------------------|
| 70F DB / 60F WB | 8.75 | 83434 |
| | 9.75 | 84933 |
| | 10.75 | 86168 |
| | 11.75 | 87201 |

MCCW-20-H-1 CFM Adjustments

| Nominal CFM vs. External Static Pressure Table | | | | | | |
|--|----------|------|------|------|------|------|
| Model Number | Hi Speed | | | | | |
| | 0.05 | 0.10 | 0.15 | 0.20 | 0.25 | 0.30 |
| MCCW-20-H-1 | 1435 | 1415 | 1400 | 1363 | 1325 | 1290 |

MCCW-20-H-1 Sound Data

| | |
|-----------|-------------|
| MODEL # | MCCW-20-H-1 |
| Fan Speed | dB @ 1 m |
| H | 46 |

MCCW-20-H-1 Dimensional Drawing

MCCW Certified Drawing
 Drawing # 0907400072

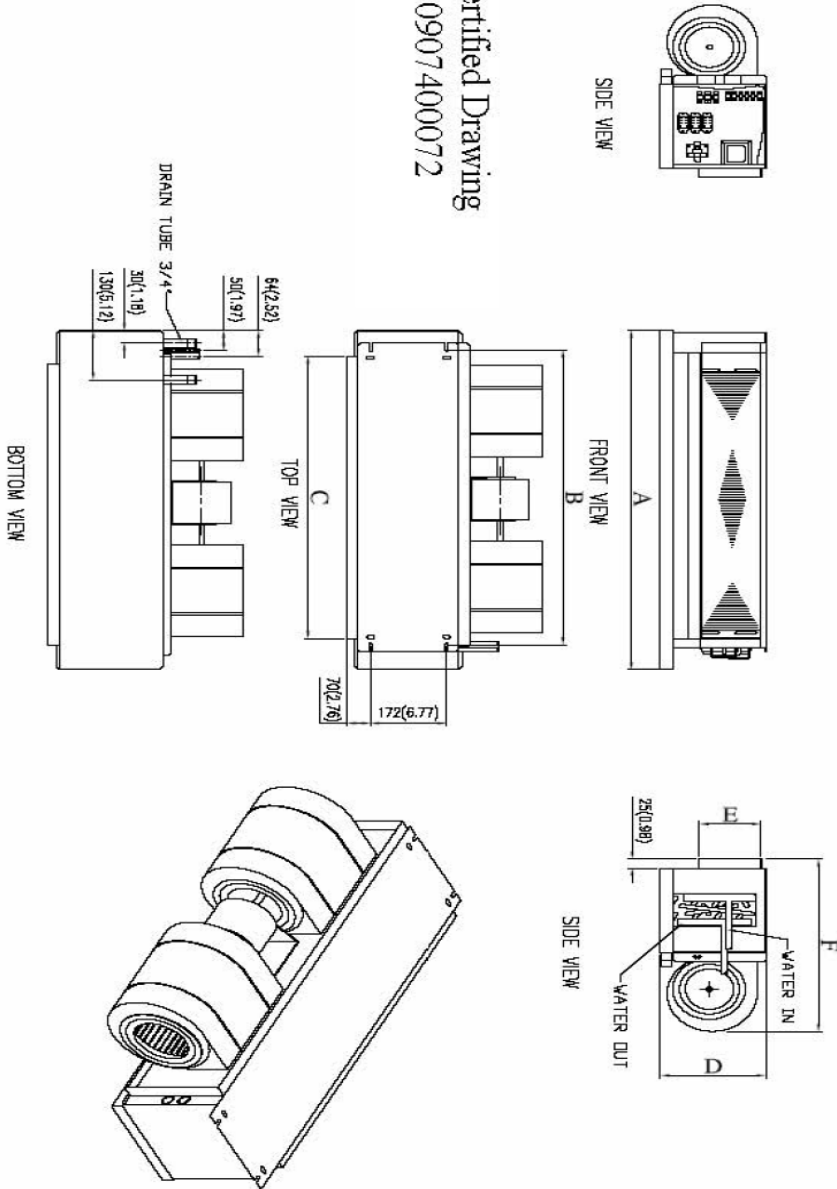

| Model MCCW | | | | | | |
|------------|-------------|-------------|-------------|------------|-----------|------------|
| MODEL | A | B | C | D | E | F |
| 04 | 958(37.72) | 843(33.19) | 801(31.54) | 247(9.72) | 139(5.47) | 455(17.91) |
| 06 | 958(37.72) | 843(33.19) | 801(31.54) | 247(9.72) | 139(5.47) | 455(17.91) |
| 08 | 958(37.72) | 843(33.19) | 801(31.54) | 247(9.72) | 139(5.47) | 455(17.91) |
| 10 | 1238(48.74) | 1123(44.21) | 1081(42.56) | 298(11.73) | 189(7.44) | 455(17.91) |
| 12 | 1238(48.74) | 1123(44.21) | 1081(42.56) | 298(11.73) | 189(7.44) | 503(19.80) |
| 16 | 1432(56.38) | 1317(51.85) | 1275(50.20) | 349(13.74) | 241(9.49) | 503(19.80) |
| 20 | 1432(56.38) | 1317(51.85) | 1275(50.20) | 349(13.74) | 241(9.49) | 503(19.80) |