



MH1WC4W-04-1-B Chilled/Hot Water 1-Way Cassette Fan Coil

4-Pipe Heat / Cool Fan Coil 12,000 BTUH

*These specifications are subject to change without notice.
Check www.multiaqua.com for latest published information.*

HVAC Guide Specifications

Chilled and Hot Water Cassette Fan Coil

4-Pipe

Nominal Size:

12,000 BTUH

MultiAqua Model Number:

MH1WC4W-04-1-B

Part 1 - General

1.01 System Description:

MultiAqua Chilled Water Fan Coils are manufactured with galvanized steel and high impact molded polymers.

1.02 Quality Assurance:

- A. ETL certified in accordance with U.L. Standard 95, latest version (U.S.A.).
- B. Manufactured in a facility registered to ISO 9002, Manufacturing Quality Standard.
- C. Fully load tested at the factory.
- D. Damage resistant packaging.

1.03 Delivery, Storage and Handling:

- A. Packaged and readied for shipment from the factory.
- B. Controls shall be capable of withstanding 150°F storage temperatures in the control compartment.

Part 2 - Product

2.01 Equipment:

- A. General:
 1. Unit shall be a factory assembled and tested water fan coil.
 2. Unit shall be assembled with high quality.
 3. Contained within the unit shall be all factory wiring, piping, and associated controls.
- B. Unit Cabinet and Cover:
 1. Cabinet is constructed of galvanized sheet metal.
 2. Cover composed of high impact polymers.
 3. Internally and externally insulated to ensure quiet operation.
- C. Fan Motor and Blower Wheel:
 1. Available in 208/230-1-50/60 VAC.
 2. Fan motor shall be three speed, direct drive, and PSC type.
 3. Fan motor shall be totally enclosed.
 4. Fan motor shall be internal overload protected.
 5. Radial blower wheel is dynamically balanced.
- D. Air Distribution:
 1. Unit contains one automatic discharge air louver.
- E. Water Coils:
 1. Manufactured with water coils containing copper tubing mechanically bonded to aluminum fins.
 2. Maximum design operating pressure shall not exceed 150 psig.
 3. Coils are designed to accept an entering water temperature not to exceed 160°F.
 4. Both coils are equipped with manual air bleed ports which drain into the units internal drain pan.
 5. Secondary coil is in the re-heat position.

- F. Drain Pan:
 - 1. Constructed of galvanized steel with baked on polyester powder coating and closed cell insulation.
 - 2. Unit contains internal lift pump and drain pan float switch designed for evacuating condensate to the fan coil unit drain port level only.
- G. Filters:
 - 1. Unit shall contain two woven panel washable filter.
- H. Fresh Air:
 - 1. Unit shall be able to receive up to 10% filtered fresh air.
 - 2. Fresh air introduced shall be externally fan forced and externally controlled.

Part 3 - Controls and Safeties

3.01 Controls:

- A. Fan coils are factory wired and tested.
- B. Fan coil includes a terminal block that is capable of incorporating a 24 VAC, field supplied thermostat.

3.02 Safeties:

- A. Fan coil contains a replaceable fuse on the low voltage side of the transformer.
- B. Coils shall be designed to accept an entering water temperature not to exceed 160°F

Part 4 - Operating Characteristics

4.01 Electrical Requirements

- A. Electrical line voltage connections shall be made at the factory supplied terminal block.
- B. Factory wiring shall be rated according to UL listing at the time of manufacturing.

4.02 Installation in high ambient/high humidity environments

- A. Cabinets are internally insulated from the factory. However, if these units are installed in high ambient/high humidity environments, additional field installed external cabinet insulation may be required.

Part 5- Definitions

5.01 Abbreviations:

- CFM = Cubic Feet per Minute
- DB = Dry Bulb Temperature
- EWT = Entering Water Temperature
- GPM = US Gallons Per Minute
- MBH = BTU X 1000
- SC = Sensible Cooling
- TC = Total Cooling = Sensible + Latent
- WB = Wet Bulb Temperature
- WPD = Water Pressure Drop in Feet of Head
- dB = Decibel Level
- m = Meter
- In = Inches
- FP I= Fins per Inch
- OD = Outside Diameter
- ID = Inside Diameter
- MCA = Minimum Circuit Amps
- MOP = Maximum Over current Protection
- lbs. = Pounds U.S.

5.02 Measurements

- A. All measurements with regard to length, width, and height shall be in inches.

MH1WC4W-04-1-B Product Specifications

Physical Data							
Model Number	Weight (lbs.)	Cabinet Dimensions (in)	Cover Dimensions (in)	Cooling Rows FPI	Heating Rows FPI	Water Inlet/Outlet (in)	Drain (in)
MH1WC4W-04-1-B	66.14	33.75 x 19.50 x 10.50 *	41.50 x 22.83 x 1.00 *	3/14	1/14	3/4 FPT	3/4 Hose Conn.

* See IOM for dimensional drawings.

Electrical Data*						
Model Number	CFM	Volts/Phase/Hertz	Motor Watts	Full Load Amps	Fuse or HACR Circuit Breaker or Glass Fuse Per Circuit	
					MCA	MOP
MH1WC4W-04-1-B	500	208/230-150/60	105	.45	.56	1

*All Electric Data Shown is at 60 Hz

MH1WC4W-04-1-B Chilled Water Performance Data (PRIMARY COIL COOLING)

MH1WC4W-04-1-B COOLING CAPACITIES (Primary Coil)				
CFM	EWT (°F)	GPM	ENTERING AIR TEMPERATURE (F)	
				80° D.B. / 67° W.B.
*500	42°	1.50	TC	11354
			SC	9386
			WPD	1.8
		2.50	TC	14460
			SC	10731
			WPD	5.0
		3.00	TC	15573
			SC	11192
			WPD	6.9
		3.75	TC	16851
			SC	11726
			WPD	10.5

***High Speed**

MH1WC4W-04-1-B COOLING CAPACITIES (Primary Coil)				
CFM	EWT (°F)	GPM	ENTERING AIR TEMPERATURE (F)	
				80° D.B. / 67° W.B.
*500	45°	1.50	TC	10267
			SC	8912
			WPD	1.8
		2.50	TC	12948
			SC	10118
			WPD	4.9
		3.00	TC	13928
			SC	10527
			WPD	6.9
		3.75	TC	15054
			SC	10994
			WPD	10.4

***High Speed**

MH1WC4W-04-1-B Hot Water Performance Data (PRIMARY COIL HEATING)

MH1WC4W-04-1-B HOT WATER CAPACITIES (Primary Coil)

ENTERING AIR (°F)	NOMINAL CFM	GPM	WPD	ENTERING WATER TEMPERATURE (°F)							
				90°	100°	110°	120°	130°	140°	150°	160°
50°	*500	.75	.5	8569	10772	13010	15280	17578	19900	22244	24606
		1.00	.9	9933	12502	15112	17760	20440	23069	25674	28281
		1.25	1.5	10950	13786	16667	19528	22365	25209	28059	30913
		1.50	2.0	11726	14762	17763	20771	23788	26815	29847	32884

MH1WC4W-04-1-B HOT WATER CAPACITIES (Primary Coil)

ENTERING AIR (°F)	NOMINAL CFM	GPM	WPD	ENTERING WATER TEMPERATURE (°F)							
				90°	100°	110°	120°	130°	140°	150°	160°
60°	*500	.75	.5	6513	8702	10928	13186	15472	17784	20118	22459
		1.00	.9	7527	10078	12671	15303	17962	20557	23157	25760
		1.25	1.5	8280	11096	13957	16784	19614	22453	25298	28147
		1.50	2.0	8854	11860	14845	17844	20855	23874	26901	29933

MH1WC4W-04-1-B HOT WATER CAPACITIES (Primary Coil)

ENTERING AIR (°F)	NOMINAL CFM	GPM	WPD	ENTERING WATER TEMPERATURE (°F)							
				90°	100°	110°	120°	130°	140°	150°	160°
70°	*500	.75	.5	4431	6609	8823	11070	13346	15648	17972	20265
		1.00	.9	5097	7631	10209	12825	15445	18036	20632	23232
		1.25	1.5	5590	8387	11220	14032	16856	19686	22529	25374
		1.50	2.0	5966	8942	11918	14910	17914	20928	23949	26976

MH1WC4W-04-1-B HOT WATER CAPACITIES (Primary Coil)

ENTERING AIR (°F)	NOMINAL CFM	GPM	WPD	ENTERING WATER TEMPERATURE (°F)							
				90°	100°	110°	120°	130°	140°	150°	160°
80°	*500	.75	.5	2325	4492	6696	8933	11199	13492	15807	18063
		1.00	.9	2644	5164	7727	10329	12919	15505	18098	20695
		1.25	1.5	2880	5659	8464	11270	14089	16917	19752	22594
		1.50	2.0	3060	6014	8983	11968	14966	17974	20991	20321

***High Speed**

MH1WC4W-04-1-B Chilled Water Performance Data (SECONDARY COIL COOLING)

MH1WC4W-04-1-B COOLING CAPACITIES (Secondary Coil)				
CFM	EWT (°F)	GPM	ENTERING AIR TEMPERATURE (F)	
				80° D.B. / 67° W.B.
*500	42°	1.00	TC	5973
			SC	5238
			WPD	6.5
		1.25	TC	6629
			SC	5508
			WPD	9.8
		1.50	TC	7220
			SC	5726
			WPD	13.8
		1.75	TC	7704
			SC	5897
			WPD	18.3

***High Speed**

MH1WC4W-04-1-B COOLING CAPACITIES (Secondary Coil)				
CFM	EWT (°F)	GPM	ENTERING AIR TEMPERATURE (F)	
				80° D.B. / 67° W.B.
*500	45°	1.00	TC	5356
			SC	4957
			WPD	6.5
		1.25	TC	5894
			SC	5231
			WPD	9.8
		1.50	TC	6328
			SC	5421
			WPD	13.7
		1.75	TC	6725
			SC	5564
			WPD	18.2

***High Speed**

MH1WC4W-04-1-B Hot Water Performance Data (SECONDARY COIL HEATING – Reheat Position)

MH1WC4W-04-1-B HOT WATER CAPACITIES (Secondary Coil)

ENTERING AIR (°F)	NOMINAL CFM	GPM	WPD	ENTERING WATER TEMPERATURE (°F)							
				90°	100°	110°	120°	130°	140°	150°	160°
50°	*500	.75	3.6	6133	7646	9171	10705	12248	13796	15350	16907
		1.00	6.2	6677	8329	9992	11665	13346	15033	16725	18421
		1.25	9.3	7049	8794	10551	12316	14089	15868	17652	19439
		1.50	12.9	7323	9136	10960	12792	14631	16476	18325	20178

MH1WC4W-04-1-B HOT WATER CAPACITIES (Secondary Coil)

ENTERING AIR (°F)	NOMINAL CFM	GPM	WPD	ENTERING WATER TEMPERATURE (°F)							
				90°	100°	110°	120°	130°	140°	150°	160°
60°	*500	.75	3.6	4670	6177	7696	9225	10763	12307	13856	15410
		1.00	6.1	5074	6719	8376	10043	11719	13401	15089	16781
		1.25	9.2	5350	7088	8838	10598	12366	14140	15919	17702
		1.50	12.9	5553	7359	9177	11003	12838	14678	16523	18372

MH1WC4W-04-1-B HOT WATER CAPACITIES (Secondary Coil)

ENTERING AIR (°F)	NOMINAL CFM	GPM	WPD	ENTERING WATER TEMPERATURE (°F)							
				90°	100°	110°	120°	130°	140°	150°	160°
70°	*500	.75	3.6	3202	4702	6216	7740	9273	10813	12359	13909
		1.00	6.1	3466	5104	6756	8418	10088	11766	13450	15138
		1.25	9.2	3647	5378	7122	8877	10640	12409	14184	15964
		1.50	12.9	3779	5579	7391	9212	11042	12878	14719	16564

MH1WC4W-04-1-B HOT WATER CAPACITIES (Secondary Coil)

ENTERING AIR (°F)	NOMINAL CFM	GPM	WPD	ENTERING WATER TEMPERATURE (°F)							
				90°	100°	110°	120°	130°	140°	150°	160°
80°	*500	.75	3.6	1727	3222	4731	6250	7779	9315	10857	12404
		1.00	6.1	1853	3485	5131	6788	8454	10127	11807	13492
		1.25	9.2	1939	3665	5403	7152	8910	10676	12447	14223
		1.50	12.8	2033	3797	5603	7419	9243	11075	12913	14754

***High Speed**

MH1WC4W-04-1-B Chilled Water Performance Data (BOTH COILS COOLING)

MH1WC4W-04-1-B COOLING CAPACITIES (Both Coils)				
CFM	EWT (°F)	GPM	ENTERING AIR TEMPERATURE (F)	
				80° D.B. / 67° W.B.
*500	42°	2.00	TC	14154
			SC	10875
			WPD	1.9
		3.00	TC	16983
			SC	12067
			WPD	4.3
		4.00	TC	18888
			SC	12874
			WPD	7.3
		5.00	TC	20218
			SC	13445
			WPD	11.1

***High Speed**

MH1WC4W-04-1-B COOLING CAPACITIES (Both Coils)				
CFM	EWT (°F)	GPM	ENTERING AIR TEMPERATURE (F)	
				80° D.B. / 67° W.B.
*500	45°	2.00	TC	12761
			SC	10299
			WPD	1.9
		3.00	TC	15210
			SC	11339
			WPD	4.3
		4.00	TC	16897
			SC	12039
			WPD	7.3
		5.00	TC	18079
			SC	12535
			WPD	11.00

***High Speed**

MH1WC4W-04-1-B Hot Water Performance Data (BOTH COILS HEATING)

MH1WC4W-04-1-B HOT WATER CAPACITIES (Both Coils)											
ENTERING AIR (°F)	NOMINAL CFM	GPM	WPD	ENTERING WATER TEMPERATURE (°F)							
				90°	100°	110°	120°	130°	140°	150°	160°
50	*500	.75	.4	8903	11144	13525	15871	18242	20635	23046	25472
		1.00	.5	10437	13129	15861	18628	21425	24249	27097	29953
		1.25	.9	11584	14580	17620	20697	23808	26901	29935	32972
		1.50	1.3	12468	15694	18965	22274	25509	28749	31995	35244
MH1WC4W-04-1-B HOT WATER CAPACITIES (Both Coils)											
ENTERING AIR (°F)	NOMINAL CFM	GPM	WPD	ENTERING WATER TEMPERATURE (°F)							
				90°	100°	110°	120°	130°	140°	150°	160°
60	*500	.75	.4	6752	8989	11358	13693	16054	18438	20840	23259
		1.00	.5	7904	10581	13297	16049	18833	21644	24479	27281
		1.25	.9	8756	11733	14753	17813	20908	23957	26987	30020
		1.50	1.3	9411	12615	15866	19134	22360	25595	28835	32079
MH1WC4W-04-1-B HOT WATER CAPACITIES (Both Coils)											
ENTERING AIR (°F)	NOMINAL CFM	GPM	WPD	ENTERING WATER TEMPERATURE (°F)							
				90°	100°	110°	120°	130°	140°	150°	160°
70	*500	.75	.4	4583	6869	9167	11493	13845	16220	18615	21026
		1.00	.5	5347	8008	10711	13449	16220	19019	21843	24601
		1.25	.9	5905	8864	11867	14911	17986	21006	24031	27060
		1.50	1.3	6334	9518	12749	15984	19204	22433	25668	28908
MH1WC4W-04-1-B HOT WATER CAPACITIES (Both Coils)											
ENTERING AIR (°F)	NOMINAL CFM	GPM	WPD	ENTERING WATER TEMPERATURE (°F)							
				90°	100°	110°	120°	130°	140°	150°	160°
80	*500	.75	.4	2396	4664	6953	9271	11615	13982	16370	18775
		1.00	.5	2765	5413	8102	10828	13587	16375	19167	21911
		1.25	.9	3032	5974	8961	11989	15029	18045	21067	24093
		1.50	1.3	3237	6403	9615	12826	16040	19264	22495	25731

***High Speed**

MH1WC4W-04-1-B CFM Data

MODEL #	MH1WC4W-04-1-B
Fan Speed	CFM
L	340
M	385
H	500
Wattage @ High Speed	105

MH1WC4W-04-1-B Sound Data

MODEL #	MH1WC4W-04-1-B
Fan Speed	dB @ 1 m
L	55.3
M	56.6
H	57.8

MH1WC4W-04-1-B Wiring Diagram

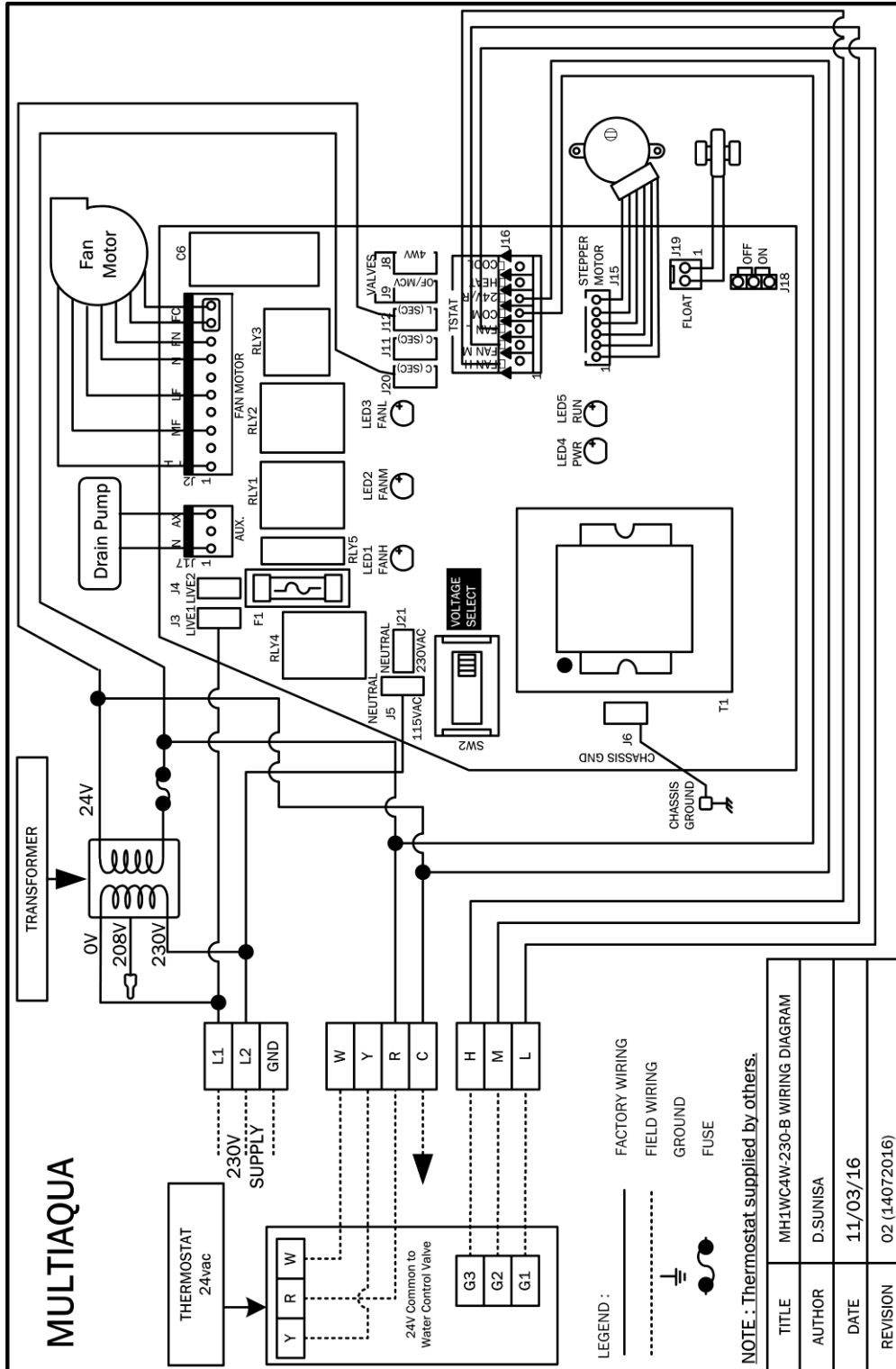

These specifications are subject to change without notice.
Check www.multiaqua.com for latest published information.

See Installation and Operation Manual
for Dimensional Drawings



306 Hagood Street
Easley, SC 29640
Ph.: 864-850-8990
Fax: 864-850-8995
www.multiaqua.com

For Technical Assistance:
1-855-THNK-WTR (1-855-846-5987)

*These specifications are subject to change without notice.
Check www.multiaqua.com for latest published information.*