



MH1WC4W-08-1-B Chilled/Hot Water 1-Way Cassette Fan Coil

4-Pipe Heat / Cool Fan Coil 24,000 BTUH

*These specifications are subject to change without notice.
Check www.multiaqua.com for latest published information.*

HVAC Guide Specifications

Chilled and Hot Water Cassette Fan Coil

4-Pipe

Nominal Size:

24,000 BTUH

MultiAqua Model Number:

MH1WC4W-08-1-B

Part 1 - General

1.01 System Description:

MultiAqua Chilled Water Fan Coils are manufactured with galvanized steel and high impact molded polymers.

1.02 Quality Assurance:

- A. ETL certified in accordance with U.L. Standard 95, latest version (U.S.A.).
- B. Manufactured in a facility registered to ISO 9002, Manufacturing Quality Standard.
- C. Fully load tested at the factory.
- D. Damage resistant packaging.

1.03 Delivery, Storage and Handling:

- A. Packaged and readied for shipment from the factory.
- B. Controls shall be capable of withstanding 150°F storage temperatures in the control compartment.

Part 2 - Product

2.01 Equipment:

- A. General:
 1. Unit shall be a factory assembled and tested water fan coil.
 2. Unit shall be assembled with high quality.
 3. Contained within the unit shall be all factory wiring, piping, and associated controls.
- B. Unit Cabinet and Cover:
 1. Cabinet is constructed of galvanized sheet metal.
 2. Cover composed of high impact polymers.
 3. Internally and externally insulated to ensure quiet operation.
- C. Fan Motor and Blower Wheel:
 1. Available in 208/230-1-50/60 VAC.
 2. Fan motor shall be three speed, direct drive, and PSC type.
 3. Fan motor shall be totally enclosed.
 4. Fan motor shall be internal overload protected.
 5. Radial blower wheel is dynamically balanced.
- D. Air Distribution:
 1. Unit contains one automatic discharge air louver.
- E. Water Coils:
 1. Manufactured with water coils containing copper tubing mechanically bonded to aluminum fins.
 2. Maximum design operating pressure shall not exceed 150 psig.
 3. Coils are designed to accept an entering water temperature not to exceed 160°F.
 4. Both coils are equipped with manual air bleed ports which drain into the units internal drain pan.
 5. Secondary coil is in the re-heat position.

- F. Drain Pan:
 - 1. Constructed of galvanized steel with baked on polyester powder coating and closed cell insulation.
 - 2. Unit contains internal lift pump and drain pan float switch designed for evacuating condensate to the fan coil unit drain port level only.
- G. Filters:
 - 1. Unit shall contain two woven panel washable filter.
- H. Fresh Air:
 - 1. Unit shall be able to receive up to 10% filtered fresh air.
 - 2. Fresh air introduced shall be externally fan forced and externally controlled.

Part 3 - Controls and Safeties

3.01 Controls:

- A. Fan coils are factory wired and tested.
- B. Fan coil includes a terminal block that is capable of incorporating a 24 VAC, field supplied thermostat.

3.02 Safeties:

- A. Fan coil contains a replaceable fuse on the low voltage side of the transformer.
- B. Coils shall be designed to accept an entering water temperature not to exceed 160°F

Part 4 - Operating Characteristics

4.01 Electrical Requirements

- A. Electrical line voltage connections shall be made at the factory supplied terminal block.
- B. Factory wiring shall be rated according to UL listing at the time of manufacturing.

4.02 Installation in high ambient/high humidity environments

- A. Cabinets are internally insulated from the factory. However, if these units are installed in high ambient/high humidity environments, additional field installed external cabinet insulation may be required.

Part 5- Definitions

5.01 Abbreviations:

- CFM = Cubic Feet per Minute
- DB = Dry Bulb Temperature
- EWT = Entering Water Temperature
- GPM = US Gallons Per Minute
- MBH = BTU X 1000
- SC = Sensible Cooling
- TC = Total Cooling = Sensible + Latent
- WB = Wet Bulb Temperature
- WPD = Water Pressure Drop in Feet of Head
- dB = Decibel Level
- m = Meter
- In = Inches
- FP I= Fins per Inch
- OD = Outside Diameter
- ID = Inside Diameter
- MCA = Minimum Circuit Amps
- MOP = Maximum Over current Protection
- lbs. = Pounds U.S.

5.02 Measurements

- A. All measurements with regard to length, width, and height shall be in inches.

MH1WC4W-08-1-B Product Specifications

Physical Data							
Model Number	Weight (lbs.)	Cabinet Dimensions (in)	Cover Dimensions (in)	Cooling Rows FPI	Heating Rows FPI	Water Inlet/Outlet (in)	Drain (in)
MH1WC4W-08-1-B	92.6	33.75 x 19.50 x 10.50 *	41.50 x 22.83 x 1.00 *	3/14	1/14	3/4 FPT	¾ Hose Conn.

* See IOM for dimensional drawings.

Electrical Data*						
Model Number	CFM	Volts/Phase/Hertz	Motor Watts	Full Load Amps	Fuse or HACR Circuit Breaker or Glass Fuse Per Circuit	
					MCA	MOP
MH1WC4W-08-1-B	579	208/230-150/60	115	.50	.63	1

*All Electric Data Shown is at 60 Hz

MH1WC4W-08-1-B Chilled Water Performance Data (PRIMARY COIL COOLING)

MH1WC4W-08-1-B COOLING CAPACITIES (Primary Coil)				
CFM	EWT (°F)	GPM	ENTERING AIR TEMPERATURE (F)	
				80° D.B. / 67° W.B.
*579	42°	2.75	TC	18418
			SC	13496
			WPD	7.7
		3.25	TC	19722
			SC	14041
			WPD	10.6
		3.75	TC	20802
			SC	14495
			WPD	13.7
		4.50	TC	22090
			SC	15033
			WPD	19.3

***High Speed**

MH1WC4W-08-1-B COOLING CAPACITIES (Primary Coil)				
CFM	EWT (°F)	GPM	ENTERING AIR TEMPERATURE (F)	
				80° D.B. / 67° W.B.
*579	45°	2.75	TC	16486
			SC	12709
			WPD	7.7
		3.25	TC	17619
			SC	13181
			WPD	10.5
		3.75	TC	18590
			SC	13580
			WPD	13.7
		4.50	TC	19716
			SC	14049
			WPD	19.1

***High Speed**

MH1WC4W-08-1-B Hot Water Performance Data (PRIMARY COIL HEATING)

MH1WC4W-08-1-B HOT WATER CAPACITIES (Primary Coil)

ENTERING AIR (°F)	NOMINAL CFM	GPM	WPD	ENTERING WATER TEMPERATURE (°F)							
				90°	100°	110°	120°	130°	140°	150°	160°
50°	*579	.75	.6	9869	12362	14880	17418	19974	22544	25125	27714
		1.00	1.2	11606	14562	17551	20567	23607	26647	29621	32594
		1.25	2.0	12933	16241	19586	22941	26245	29554	32865	36176
		1.50	2.8	13965	17543	21107	24657	28215	31778	35344	38912

MH1WC4W-08-1-B HOT WATER CAPACITIES (Primary Coil)

ENTERING AIR (°F)	NOMINAL CFM	GPM	WPD	ENTERING WATER TEMPERATURE (°F)							
				90°	100°	110°	120°	130°	140°	150°	160°
60°	*579	.75	.6	7493	9978	12487	15018	17567	20131	22705	25289
		1.00	1.2	8788	11732	14708	17713	20742	23739	26712	29683
		1.25	2.0	9775	13067	16397	19714	23014	26319	29627	32925
		1.50	2.8	10542	14101	17636	21180	24733	28291	31854	35418

MH1WC4W-08-1-B HOT WATER CAPACITIES (Primary Coil)

ENTERING AIR (°F)	NOMINAL CFM	GPM	WPD	ENTERING WATER TEMPERATURE (°F)							
				90°	100°	110°	120°	130°	140°	150°	160°
70°	*579	.75	.6	5092	7570	10073	12598	15140	17698	20268	22844
		1.00	1.2	5946	8878	11844	14839	17853	20823	23794	26764
		1.25	2.0	6595	9872	13188	16478	19774	23076	26381	29687
		1.50	2.8	7098	10630	14156	17695	21242	24797	28355	31917

MH1WC4W-08-1-B HOT WATER CAPACITIES (Primary Coil)

ENTERING AIR (°F)	NOMINAL CFM	GPM	WPD	ENTERING WATER TEMPERATURE (°F)							
				90°	100°	110°	120°	130°	140°	150°	160°
80°	*579	.75	.6	2669	5141	7638	10158	12695	15248	17814	20356
		1.00	1.2	3081	6004	8960	11945	14930	17898	20868	23839
		1.25	2.0	3394	6657	9948	13233	16526	19825	23128	26432
		1.50	2.8	3636	7147	10688	14202	17745	21296	24852	28410

***High Speed**

MH1WC4W-08-1-B Chilled Water Performance Data (SECONDARY COIL COOLING)

MH1WC4W-08-1-B COOLING CAPACITIES (Secondary Coil)				
CFM	EWT (°F)	GPM	ENTERING AIR TEMPERATURE (F)	
				80° D.B. / 67° W.B.
*579	42°	.75	TC	6460
			SC	5954
			WPD	5.1
		1.00	TC	7446
			SC	6567
			WPD	8.6
		1.25	TC	8259
			SC	6971
			WPD	13.0
		1.50	TC	8971
			SC	7259
			WPD	18.1

***High Speed**

MH1WC4W-08-1-B COOLING CAPACITIES (Secondary Coil)				
CFM	EWT (°F)	GPM	ENTERING AIR TEMPERATURE (F)	
				80° D.B. / 67° W.B.
*579	45°	.75	TC	5865
			SC	5619
			WPD	5.1
		1.00	TC	6713
			SC	6200
			WPD	8.6
		1.25	TC	7397
			SC	6599
			WPD	13.0
		1.50	TC	7969
			SC	6879
			WPD	18.1

***High Speed**

MH1WC4W-08-1-B Hot Water Performance Data (SECONDARY COIL HEATING)

MH1WC4W-08-1-B HOT WATER CAPACITIES (Secondary Coil)

ENTERING AIR (°F)	NOMINAL CFM	GPM	WPD	ENTERING WATER TEMPERATURE (°F)							
				90°	100°	110°	120°	130°	140°	150°	160°
50°	*579	.75	4.9	7433	9263	11103	12953	14809	16670	18535	20402
		1.00	8.2	8202	10231	12270	14319	16374	18436	20501	22570
		1.25	12.4	8737	10901	13077	15261	17453	19651	21852	24057
		1.5	16.9	9128	11390	13664	15946	18235	20530	22829	25130

MH1WC4W-08-1-B HOT WATER CAPACITIES (Secondary Coil)

ENTERING AIR (°F)	NOMINAL CFM	GPM	WPD	ENTERING WATER TEMPERATURE (°F)							
				90°	100°	110°	120°	130°	140°	150°	160°
60°	*579	.75	4.9	5653	7478	9313	11158	13010	14868	16729	18594
		1.00	8.2	6225	8247	10280	12324	14375	16432	18493	20558
		1.25	12.4	6622	8779	10949	13128	15314	17507	19705	21906
		1.5	16.9	6912	9168	11435	13712	15996	18286	20580	22879

MH1WC4W-08-1-B HOT WATER CAPACITIES (Secondary Coil)

ENTERING AIR (°F)	NOMINAL CFM	GPM	WPD	ENTERING WATER TEMPERATURE (°F)							
				90°	100°	110°	120°	130°	140°	150°	160°
70°	*579	.75	4.9	3866	5685	7517	9357	11206	13060	14918	16780
		1.00	8.2	4241	6257	8285	10324	12370	14423	16481	18543
		1.25	12.4	4502	6653	8816	10990	13172	15360	17554	19752
		1.5	16.9	4692	6941	9202	11474	13753	16039	18330	20624

MH1WC4W-08-1-B HOT WATER CAPACITIES (Secondary Coil)

ENTERING AIR (°F)	NOMINAL CFM	GPM	WPD	ENTERING WATER TEMPERATURE (°F)							
				90°	100°	110°	120°	130°	140°	150°	160°
80°	*579	.75	4.9	2071	3886	5713	7550	9395	11247	13103	14962
		1.00	8.2	2251	4262	6285	8319	10361	12411	14465	16524
		1.25	12.4	2377	4522	6680	8848	11026	13211	15401	17595
		1.5	16.9	2468	4711	6967	9233	11507	13789	16076	18368

***High Speed**

MH1WC4W-08-1-B Chilled Water Performance Data (BOTH COILS COOLING)

MH1WC4W-08-1-B COOLING CAPACITIES (Both Coils)				
CFM	EWT (°F)	GPM	ENTERING AIR TEMPERATURE (F)	
				80° D.B. / 67° W.B.
*579	42°	3.00	TC	20694
			SC	14755
			WPD	5.6
		3.50	TC	22035
			SC	15319
			WPD	7.4
		4.25	TC	23647
			SC	16005
			WPD	10.6
		5.50	TC	25580
			SC	16838
			WPD	17.1

***High Speed**

MH1WC4W-08-1-B COOLING CAPACITIES (Both Coils)				
CFM	EWT (°F)	GPM	ENTERING AIR TEMPERATURE (F)	
				80° D.B. / 67° W.B.
*579	45°	3.00	TC	18544
			SC	13860
			WPD	5.5
		3.50	TC	19713
			SC	14351
			WPD	7.4
		4.25	TC	21137
			SC	14943
			WPD	10.5
		5.50	TC	22873
			SC	15671
			WPD	17.0

***High Speed**

MH1WC4W-08-1-B Hot Water Performance Data (BOTH COILS HEATING)

MH1WC4W-08-1-B HOT WATER CAPACITIES (Both Coils)											
ENTERING AIR (°F)	NOMINAL CFM	GPM	WPD	ENTERING WATER TEMPERATURE (°F)							
				90°	100°	110°	120°	130°	140°	150°	160°
50°	*579	.75	.5	10172	12699	15243	17918	20528	23148	25776	28407
		1.00	.7	12075	15141	18234	21350	24486	27637	30801	33973
		1.25	1.2	13550	17006	20496	24013	27554	31115	34596	38068
		1.50	1.8	14710	18472	22269	26098	29892	33658	37425	41191
MH1WC4W-08-1-B HOT WATER CAPACITIES (Both Coils)											
ENTERING AIR (°F)	NOMINAL CFM	GPM	WPD	ENTERING WATER TEMPERATURE (°F)							
				90°	100°	110°	120°	130°	140°	150°	160°
60°	*579	.75	.5	7707	10234	12852	15444	18048	20664	23287	25914
		1.00	.7	9138	12193	15276	18383	21510	24653	27809	30974
		1.25	1.2	10236	13679	17155	20660	24189	27711	31184	34655
		1.50	1.8	11099	14844	18625	22439	26199	29961	33725	37489
MH1WC4W-08-1-B HOT WATER CAPACITIES (Both Coils)											
ENTERING AIR (°F)	NOMINAL CFM	GPM	WPD	ENTERING WATER TEMPERATURE (°F)							
				90°	100°	110°	120°	130°	140°	150°	160°
70°	*579	.75	.5	5227	7792	10362	12949	15549	18161	20780	23404
		1.00	.7	6176	9222	12296	15395	18514	21650	24799	27928
		1.25	1.2	6900	10329	13793	17286	20805	24292	27763	31233
		1.50	1.8	7467	11196	14963	18744	22498	26257	30018	33780
MH1WC4W-08-1-B HOT WATER CAPACITIES (Both Coils)											
ENTERING AIR (°F)	NOMINAL CFM	GPM	WPD	ENTERING WATER TEMPERATURE (°F)							
				90°	100°	110°	120°	130°	140°	150°	160°
80°	*579	.75	.5	2731	5287	7852	10435	13033	15641	18257	20880
		1.00	.7	3192	6230	9296	12388	15500	18630	21773	24871
		1.25	1.2	3541	6959	10412	13895	17397	20866	24336	27805
		1.50	1.8	3814	7529	11282	15038	18789	22546	26306	30066

***High Speed**

MH1WC4W-08-1-B CFM Data

MODEL #	MH1WC4W-08-1-B
Fan Speed	CFM
L	445
M	500
H	579
Wattage @ High Speed	115

MH1WC4W-08-1-B Sound Data

MODEL #	MH1WC4W-08-1-B
Fan Speed	dB @ 1 m
L	55.5
M	57.7
H	60.1

MH1WC4W-08-1-B Wiring Diagram

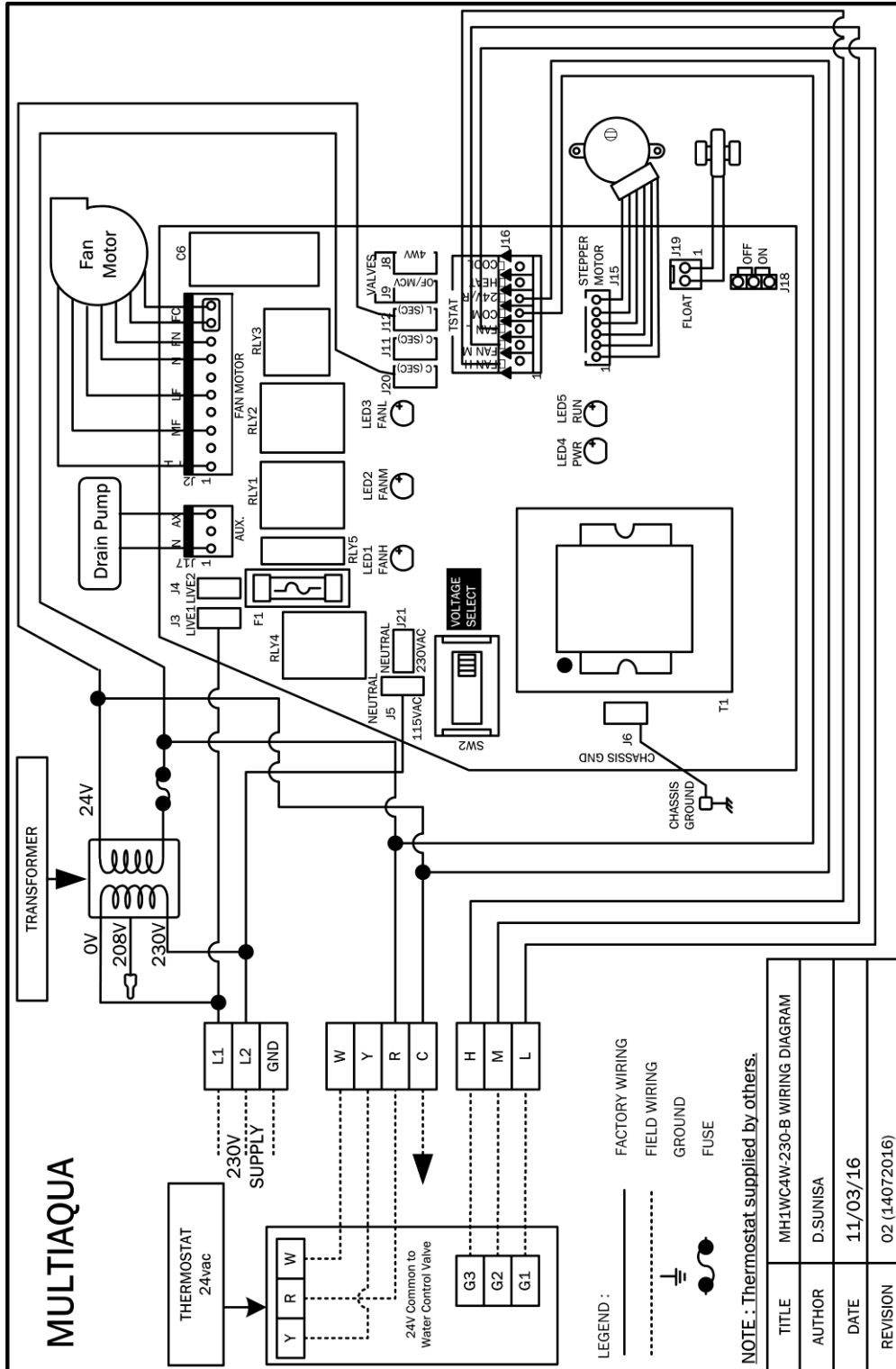

These specifications are subject to change without notice.
 Check www.multiaqua.com for latest published information.

See Installation and Operation Manual
for Dimensional Drawings



306 Hagood Street
Easley, SC 29640
Ph.: 864-850-8990
Fax: 864-850-8995
www.multiaqua.com

For Technical Assistance:
1-855-THNK-WTR (1-855-846-5987)

*These specifications are subject to change without notice.
Check www.multiaqua.com for latest published information.*