



# MHCCW-04-02-03 Chilled Water Ceiling Concealed with **2kW** Electric Heat (115V)

2-Pipe Heat / Cool Fan Coil 12,000 BTUH

# HVAC Guide Specifications

Chilled or Hot Water Fan Coil with Electric Heat  
2-Pipe

Nominal Size:  
**12,000 BTUH**

MultiAqua Model Number:  
**MHCCW-04-02-03**

## **Part 1-General**

### **1.01 System Description**

MultiAqua Chilled Water Fan Coils are manufactured with heavy gauge galvanized steel to resist corrosion.

### **1.02 Quality Assurance**

- A. Certified in accordance with U.L. Standard 95, latest version (U.S.A.)
- B. Manufactured in a facility registered to ISO 9002, Manufacturing Quality Standard.
- C. Fully load tested at the factory.
- D. Damage resistant packaging.

### **1.03 Delivery, Storage and Handling**

- A. Packaged and readied for shipment from the factory.
- B. Controls shall be capable of withstanding 150°F storage temperatures in the control compartment.
- C. Stored and handled per manufacturer's recommendations.

## **Part 2-Product**

### **2.01 Equipment**

- A. General:
  1. Unit shall be a factory assembled and tested chilled or hot water fan coil.
  2. Shall be assembled with heavy gauge galvanized steel.
  3. Contained with the unit shall be all factory wiring, piping, associated controls and special accessories required prior to start up.
- B. Unit Cabinet:
  1. Composed of heavy gauge galvanized steel casing with a baked polyester powder.
  2. Shall be internally insulated to ensure quiet operation.
- C. Fan Motors:
  1. Shall be available in 115-1-60 VAC.
  2. Fan motors shall be three-speed, direct drive, and PSC type.
  3. Totally enclosed.
  4. Internal overload protected.
- D. Blower Wheels:
  1. Blower wheels are forward curved and dynamically balanced.
- E. Water Coil:
  1. Manufactured with water coils containing 3/8" copper tubing mechanically bonded to aluminum fins.
  2. Contain both a manual water drain and manual air bleed port per coil.
  3. Maximum operating pressure is 150 psig.
  4. Coils shall be capable of being field converted from right to left hand connection.
- F. Drain Pan:
  1. All drain pans shall be coated on both the interior and exterior with baked polyester powder to resist corrosion.
  2. The exterior of all drain pans shall be insulated with closed cell insulation to prevent condensation.
  3. Pans shall contain a left and right hand primary sloped drain connection as well as a sloped right hand secondary drain connection.

*These specifications are subject to change without notice.  
Check [www.multiAqua.com](http://www.multiAqua.com) for the latest information.*

- G. Electric Heat:
  1. Electric Heaters shall be of the rod and disk type.
  2. Shall be protected by safeties.

**Part 3-Controls and Safeties**

**3.01 Controls**

- A. Fan coils shall be completely factory wired and tested.
- B. All components shall be wired to an internal terminal block to allow for a field installed thermostat and or Fan speed control.
- C. Controls shall include the following components.
  1. 24vac transformer.
  2. Fan relays.
  3. Electric Heat Sequencer(s).
  4. Optional Thermostats.

**3.02 Safeties**

- A. Fan coil shall be equipped with all necessary components in conjunction with the control system to provide the following protectants.
  1. High temperature.
  2. Over current protection.

**Part 4-Operating Characteristics**

**4.01 Electrical Requirements**

- A. Primary electrical power supply shall enter the unit at a single location.
- B. Electrical power supply shall be rated to withstand 120°F operating ambient temperatures.
- C. Control and high voltage points shall be accessed through terminal block.

**Part 5- Accessories:**

**5.01 Enclosures**

- A. Fan coils shall be capable of incorporating field assembled enclosures.
  1. Enclosures shall be internally insulated to ensure quiet operation and increase efficiency.
  2. Shall include knockouts for ease of piping and electrical in and out of the enclosures.
  3. Shall include an optional return air cutout in the enclosure.
  4. Shall include a supply air duct flange.
  5. Shall incorporate baked polyester powder service access panels with and without a filtered louver.

**Part 6- Definitions**

**6.01 Abbreviations**

- A. CFM = Cubic Feet per Minute
- B. DB = Dry Bulb Temperature
- C. EWT = Entering Water Temperature
- D. GPM = US Gallons Per Minute
- E. MBH = BTU X 1000
- F. SC = Sensible Cooling
- G. TC = Total Cooling = Sensible + Latent
- H. WB = Wet Bulb Temperature
- I. WPD = Water Pressure Drop in feet of head
- J. dB = Decibel Level
- K. m = Meter
- L. In = Inches
- M. FPI = Fins per Inch
- N. OD = Outside Diameter
- O. ID = Inside Diameter
- P. MCA = Minimum Circuit Amps
- Q. MOP = Maximum Over current Protection
- R. LBS = Pounds U.S.

**6.02 Measurements**

- A. All measurements with regard to length, width, and height shall be in inches

# MHCCW-04-02-03 Product Specifications

Physical Data									
Model Number	Height (in)	Width (in)	Depth (in)	Weight (lbs)	Coil Rows FPI	Copper Diameter (in)	Water Inlet (in)	Water Outlet (in)	Drain (in)
MHCCW-04-02-03	10.25	37.72	21.65	66.0	2-14	3/8	5/8	5/8	3/4

Electrical Data							
Model Number	Nominal CFM	Volts Phase Hertz	Electric Heat (KW)	Fan Motor HP	Full Load Ampacity	Fuse or HACR Circuit Breaker Per Circuit	
						MCA	MOP
MHCCW-04-02-03	400	115-1-60	2	1/30	18.17	18.37	20

External Static Pressure Comparative CFM Table							
Model Number	0.00*	0.05*	0.10*	0.15*	0.2*	0.25*	0.30*
<b>MHCCW-04</b>	<b>322</b>	<b>290</b>	<b>252</b>	<b>220</b>	<b>0</b>	<b>0</b>	<b>0</b>
MHCCW-06	715	684	653	622	591	565	538
MHCCW-08	915	879	814	809	774	734	693
MHCCW-10	1007	975	944	898	853	817	780
MHCCW-12	1254	1218	1183	1147	1112	1076	1041
MCCW-16	1435	1394	1354	1313	1272	1231	1191
MCCW-20	1450	1409	1368	1327	1285	1244	1203

\* External static pressure (In W.G.)

These specifications are subject to change without notice.  
Check [www.multiaqua.com](http://www.multiaqua.com) for the latest information.

# MHCCW-04-02-03 Chilled Water Performance Data

<b>MHCCW-04-02-03 COOLING CAPACITIES</b>				
CFM	EWT (°F)	GPM	ENTERING AIR TEMPERATURE (F)	
				80° D.B. / 67° W.B.
300	42	1.5	TC	8833
			SC	6474
			WPD	3.8
		2.5	TC	10890
			SC	7471
			WPD	9.9
		3.0	TC	111543
			SC	7773
			WPD	13.9
		3.75	TC	12209
			SC	8095
			WPD	21.0

**\*High Speed**

<b>MHCCW-04-02-03 COOLING CAPACITIES</b>				
CFM	EWT (°F)	GPM	ENTERING AIR TEMPERATURE (F)	
				80° D.B. / 67° W.B.
300	45	1.5	TC	7897
			SC	6126
			WPD	3.8
		2.5	TC	9673
			SC	6974
			WPD	9.8
		3.0	TC	10280
			SC	7251
			WPD	13.8
		3.75	TC	10865
			SC	7519
			WPD	20.9

**\*High Speed**

**Recommended minimum flow rate for this unit at  $\geq 2$  fps is 1.5 gpm**

**Recommended maximum flow rate for this unit at  $\leq 6$  fps is 3.75 gpm**

*These specifications are subject to change without notice.  
Check [www.multiaqua.com](http://www.multiaqua.com) for the latest information.*

# MHCCW-04-02-03 Hot Water Performance Data

MHCCW-04-02-03 HOT WATER CAPACITIES													
ENTERING AIR (°F)	NOMINAL CFM	GPM	WPD	ENTERING WATER TEMPERATURE (°F)									
				90°	100°	110°	120°	130°	140°	150°	160°	170°	180°
50	300	1.5	3.6	8450	10584	12730	14884	17045	19212	21383	23557	25734	27912
		2.5	9.1	9203	11521	13848	16181	18520	20864	23211	25560	27912	30264
		3.0	12.7	9409	11776	14151	16532	18918	21308	23701	26097	28494	30892
		3.75	19.3	9622	12040	14464	16894	19328	21766	24206	26648	29092	31537

MHCCW-04-02-03 HOT WATER CAPACITIES													
ENTERING AIR (°F)	NOMINAL CFM	GPM	WPD	ENTERING WATER TEMPERATURE (°F)									
				90°	100°	110°	120°	130°	140°	150°	160°	170°	180°
60	300	1.5	3.5	6362	8490	10629	12777	14933	17095	19262	21433	23607	25782
		2.5	9.1	6921	9233	11554	13883	16218	18558	20901	23248	25597	27947
		3.0	12.7	7074	9435	11805	14182	16565	18951	21341	23734	26129	28525
		3.75	19.2	7232	9645	12065	14491	16922	19357	21794	24234	26676	29119

MHCCW-04-02-03 HOT WATER CAPACITIES													
ENTERING AIR (°F)	NOMINAL CFM	GPM	WPD	ENTERING WATER TEMPERATURE (°F)									
				90°	100°	110°	120°	130°	140°	150°	160°	170°	180°
70	300	1.5	3.5	4270	6391	8524	10667	12818	14976	17139	19306	21476	23649
		2.5	9.1	4637	6943	9259	11583	13914	16250	18590	20933	23279	25627
		3.0	12.7	4841	7093	9458	11831	14209	16292	18979	21369	23762	26156
		3.75	19.2	6391	7249	9665	12087	14514	16946	19381	21818	24258	26699

MHCCW-04-02-03 HOT WATER CAPACITIES													
ENTERING AIR (°F)	NOMINAL CFM	GPM	WPD	ENTERING WATER TEMPERATURE (°F)									
				90°	100°	110°	120°	130°	140°	150°	160°	170°	180°
80	300	1.5	3.5	2174	4289	6416	8554	10700	12854	15013	17177	19345	21515
		2.5	9.0	2351	4651	6962	9282	11608	13941	16278	18619	20962	23308
		3.0	12.7	2399	4750	7110	9479	11853	14233	16618	19005	21395	23787
		3.75	19.2	2449	4852	7264	9682	12107	14535	16968	19403	21841	24280

Heating at ANSI/AHRI 440 with addendum 1, 6.3.2 Table 1 as follows:

ENTERING AIR TEMPERATURE	GPM	ENTERING WATER TEMPERATURE 140F
70F DB / 60F WB	1.5	15078
	2.5	16378
	3.0	16726
	3.75	17087

These specifications are subject to change without notice.  
Check [www.multiaqua.com](http://www.multiaqua.com) for the latest information.

## MHCCW-04-02-03 Electric Heat Performance Data

Model Number	Nominal CFM	Electric Heat BTUH
MHCCW-04-02-03	300	6,800

## MHCCW-04-02-03 Sound Data

MODEL #	MHCCW-04-02-03
Fan Speed	dB @ 1 m
H	42

# MHCCW-04-02-03 Dimensional Drawing

MHCCW Certified Drawing  
 Drawing # 0907400070

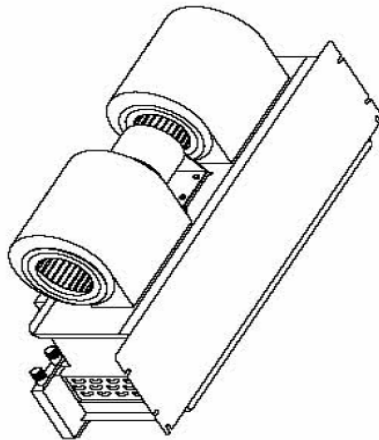
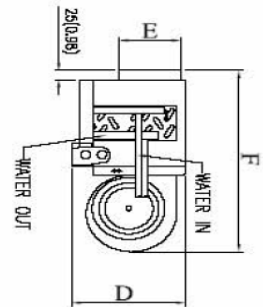
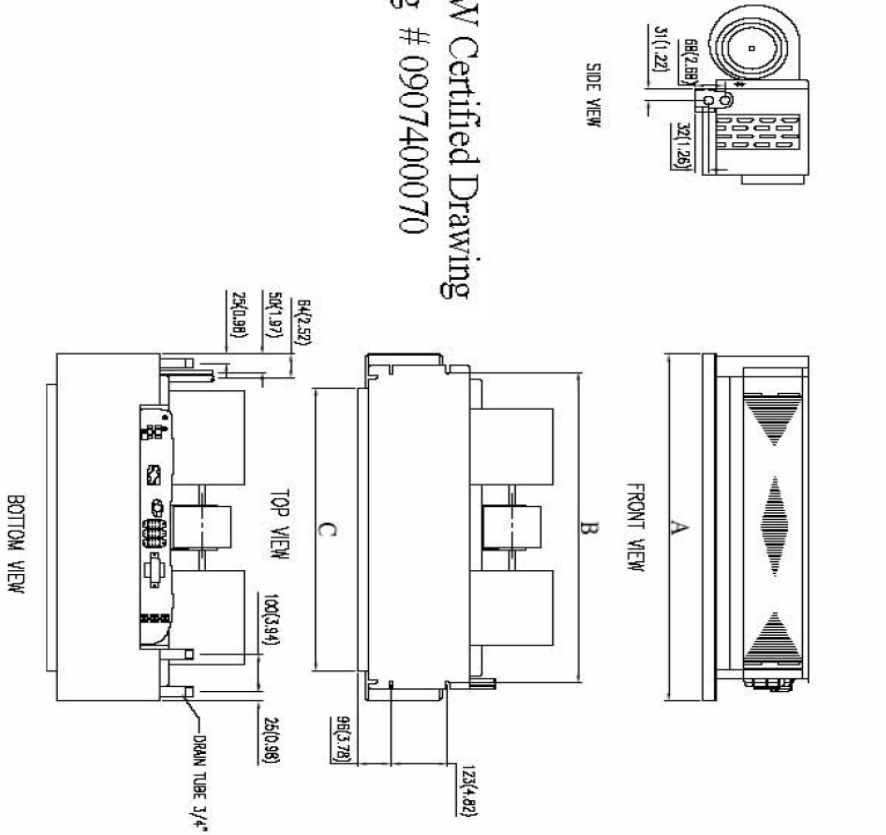

Model MHCCW						
MODEL	A	B	C	D	E	F
04	958(37.72)	878(34.57)	798(31.42)	260(10.24)	140(5.51)	550(21.65)
06	958(37.72)	878(34.57)	798(31.42)	260(10.24)	140(5.51)	550(21.65)
08	958(37.72)	878(34.57)	798(31.42)	260(10.24)	140(5.51)	550(21.65)
10	1110(43.70)	1030(40.55)	950(37.40)	260(10.24)	140(5.51)	550(21.65)
12	1262(49.69)	1182(46.54)	1102(43.38)	260(10.24)	140(5.51)	550(21.65)