



MHWW-09-H-1 Chilled/Hot Water Hi-Wall Fan Coil

Heat / Cool Fan Coil 9,000 BTUH

Rev. 1.4

HVAC Guide Specifications

Chilled and Hot Water Hi-Wall Fan Coil
2-Pipe

Nominal Size:
9,000 BTUH

MultiAqua Model Number:
MHWW-09-H-1

Part 1-General

1.01 System Description

MultiAqua Chilled Water Fan Coils are manufactured with high impact molded polymers.

1.02 Quality Assurance

- A. Certified in accordance with U.L. Standard 95, latest version (U.S.A.)
- B. Manufactured in a facility registered to ISO 9002, Manufacturing Quality Standard.
- C. Fully load tested at the factory.
- D. Damage resistant packaging.

1.03 Delivery, Storage and Handling

- A. Packaged and readied for shipment from the factory.
- B. Controls shall be capable of withstanding 150°F storage temperatures in the control compartment.
- C. Stored and handled per manufacturer's recommendations.

Part 2-Product

2.01 Equipment

- A. General:
 - 1. Unit shall be a factory assembled and tested chilled and hot water fan coil.
 - 2. Shall be assembled with high quality.
 - 3. Contained with the unit shall be all factory wiring, piping, associated controls and special accessories required prior to start up.
- B. Unit Cabinet:
 - 1. Composed of high impact polymers.
 - 2. Shall be internally insulated to ensure quiet operation.
- C. Fan Motors:
 - 1. Shall be 208/230-1-50/60 VAC.
 - 2. Fan motors shall be three speed, direct drive, and PSC type.
 - 3. Totally enclosed.
 - 4. Internal overload protected.
 - 5. Unit shall contain a swing motor to modulate the discharge air.
- D. Blower Wheels:
 - 1. Blower wheels are dynamically balanced.
- E. Water Coil:
 - 1. Manufactured with water coils containing 3/8" copper tubing mechanically bonded to aluminum fins.
 - 2. Maximum operating pressure is 150 psi.
 - 3. Maximum inlet water temperature 160 F.
- F. Drain Pan:
 - 1. All drain pans shall be molded with high impact polymers.
 - 2. The exterior of all drain pans shall be insulated with closed cell insulation to prevent condensation.
 - 3. Pans shall contain flexible drain tubing that is accessible from the back of the unit.
- G. Filters:
 - 1. Unit shall contain washable filters.

Part 3-Controls and Safeties**3.01 Controls**

- A. Fan coils shall be completely factory wired and tested.
- B. Controls shall include a circuit board, room sensor, indoor coil thermistor, transformer and wireless remote.
- C. Controls shall be capable of incorporating an optional hard-wired thermostat.

3.02 Safeties:

- A. Fan coil shall contain a non reusable fuse on the secondary voltage side of the transformer.

Part 4-Operating Characteristics:**4.01 Electrical Requirements**

- A. Unit shall be supplied with a three prong male primary electrical power cord.
- B. Electrical power supply shall be rated to withstand 120°F operating ambient temperatures.

Part 5- Definitions:**5.01 Abbreviations**

- A. CFM = Cubic Feet per Minute
- B. DB = Dry Bulb Temperature
- C. EWT = Entering Water Temperature
- D. GPM = US Gallons Per Minute
- E. MBH = BTU X 1000
- F. SC = Sensible Cooling
- G. TC = Total Cooling = Sensible + Latent
- H. WB = Wet Bulb Temperature
- I. WPD = Water Pressure Drop in feet of head
- J. dB = Decibel Level
- K. m = Meter
- L. In = Inches
- M. FPI = Fins per Inch
- N. OD = Outside Diameter
- O. ID = Inside Diameter
- P. MCA = Minimum Circuit Amps
- Q. MOP = Maximum Over current Protection
- R. LBS = Pounds U.S.

5.02 Measurements

- A. All measurements with regard to length, width, and height shall be in inches.

MHWW-09-H-1 Product Specifications

Physical Data									
Model Number	Height (in)	Length (in)	Depth (in)	Weight (lbs)	Cooling Rows FPI	Copper Diameter (in)	Water Inlet (in)	Water Outlet (in)	Drain (in)
MHWW-09-H-1	11.70	34.65	6.70	25.70	2-18	3/8	1/2	1/2	1/2

Electrical Data						
Model Number	Hi Speed CFM	Volts/Phase/Hertz	Fan Motor HP	Full Load Ampacity	Fuse or HACR Circuit Breaker Per Circuit	
					MCA	MOP
MHWW-09-H-1	270	208/230-1-50/60	1/60	.15/.17-.16/.19	.24-.27	5

MHWW-09-H-1 Chilled Water Performance Data

MHWW-09-H-1 COOLING CAPACITIES				
CFM	EWT (°F)	GPM	ENTERING AIR TEMPERATURE (°F)	
				80° D.B. / 67° W.B.
270*	42	2.0	TC	8565
			SC	6363
			WPD	3.2
		2.5	TC	9375
			SC	6705
			WPD	4.9
		3.0	TC	9997
			SC	6977
			WPD	7.0
		3.5	TC	10498
			SC	7213
			WPD	9.4

*High Speed

MHWW-09-H-1 COOLING CAPACITIES				
CFM	EWT (°F)	GPM	ENTERING AIR TEMPERATURE (°F)	
				80° D.B. / 67° W.B.
270*	45	2.0	TC	7671
			SC	5956
			WPD	3.2
		2.5	TC	8372
			SC	6317
			WPD	4.9
		3.0	TC	8938
			SC	6549
			WPD	7.0
		3.5	TC	9380
			SC	6739
			WPD	9.4

*High Speed

Recommended minimum flow rate for this unit at \geq 2fps is 2.0 gpm

Recommended maximum flow rate for this unit at \leq 6fps is 5.75 gpm

MHWW-09-H-1 Hot Water Performance Data

This heating performance data is at dry bulb temperature indicated / wet bulb temperature not considered

MHWW-09-H-1 HEATING CAPACITIES											
ENTERING AIR (°F)	CFM	GPM	WPD	ENTERING WATER TEMPERATURE (°F)							
				90°	100°	110°	120°	130°	140°	150°	160°
50	270	2.0	3.1	8086	10149	12227	14316	16415	18521	20633	22750
		2.5	4.7	8380	10514	12659	14815	16979	19150	21326	23506
		3.0	6.6	8588	10769	12962	15164	17372	19587	21807	24030
		3.5	8.9	8742	10929	13186	15421	17663	19910	22161	24416

MHWW-09-H-1 HEATING CAPACITIES											
ENTERING AIR (°F)	CFM	GPM	WPD	ENTERING WATER TEMPERATURE (°F)							
				90°	100°	110°	120°	130°	140°	150°	160°
60	270	2.0	3.1	6078	8133	10202	12284	14376	16476	18582	20694
		2.5	4.7	6297	8422	10560	12709	14867	17032	19203	21378
		3.0	6.6	6451	8625	10811	13006	15209	17419	19634	21853
		3.5	8.9	6566	8776	10996	13225	15462	17704	19951	22203

MHWW-09-H-1 HEATING CAPACITIES											
ENTERING AIR (°F)	CFM	GPM	WPD	ENTERING WATER TEMPERATURE (°F)							
				90°	100°	110°	120°	130°	140°	150°	160°
70	270	2.0	3.1	4067	6113	8174	10249	12334	14428	16530	18637
		2.5	4.7	4211	6328	8459	10601	12753	14912	17079	19250
		3.0	6.6	4313	6479	8658	10847	13045	15250	17460	19676
		3.5	8.9	4388	6591	8805	11029	13260	15498	17742	19989

MHWW-09-H-1 HEATING CAPACITIES											
ENTERING AIR (°F)	CFM	GPM	WPD	ENTERING WATER TEMPERATURE (°F)							
				90°	100°	110°	120°	130°	140°	150°	160°
80	270	2.0	3.0	2052	4089	6143	8211	10290	12378	14474	16577
		2.5	4.7	2122	4231	6355	8489	10636	12791	14952	17119
		3.0	6.6	2172	4330	6503	8686	10879	13079	15285	17496
		3.5	8.9	2208	4404	6612	8831	11057	13291	15530	17774

Heating at ANSI/AHRI 440 with addendum 1, 6.3.2 Table 1 as follows:

ENTERING AIR TEMPERATURE	GPM	ENTERING WATER TEMPERATURE 140°F
70°F DB / 60°F WB	2.0	14540
	2.5	15034
	3.0	15379
	3.5	15633

MHWW-09-H-1 Sound Data

MODEL #	MHWW-09-H-1
Fan Speed	dB @ 1 m
H	34
M	33
L	32

MHWW-09-H-1 Dimensional Drawing

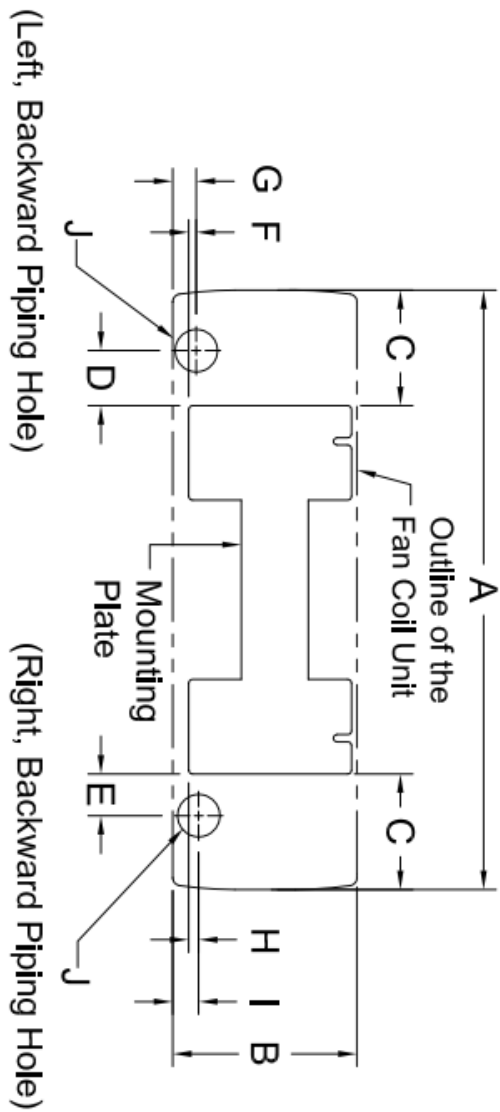

FIGURE 2

MODEL	A	B	C	D	E	F	G	H	I	J
MHWW-09-H-1	34.6	11.7	7.5	3.5	2.7	0.8	1.4	1.0	1.6	Ø2.76
MHWW-12-H-1	39.0	12.0	7.5	3.6	2.7	0.9	1.8	1.1	2.0	Ø2.76

Dimensions are in inches.